

Krantz

Floor displacement outlet Q-B-DN 200

Air distribution systems

Krantz

Floor displacement outlet

Construction design

Preliminary remarks

Floor displacement outlets are usually used where wall or plinth displacement outlets cannot be installed for reasons of space and a raised floor is available. The Q-B-DN 200 floor displacement outlet is suitable for the relatively large volume flow rate range up to 28 l/s [100 m³/h]. The air outlet element is made of aluminium and is intended for installation in conventional raised floor systems.

Construction design

The Q-B-DN 200 floor displacement outlet consists of the circular air outlet element **1** with 16 outer air slots **1a** and a perforated air outlet centre **1b**. It can be inserted either in the stepped bore **9b** or, using a clamp insert **5**, in the through bore **9a** of the floor tile. The clamp insert has a protective collar **6** on the top which functions as edging for the tile cutout. This is particularly useful for raised floors with carpeting.



Figure 1: Floor displacement outlet in a floor tile

Left: in a stepped bore

Right: in a through bore with clamp insert

The clamp insert can be fastened to the floor tile with a claw fastener **5b** or a clamp collar **5d**. The air outlet element can be optionally locked to prevent unauthorized removal ¹⁾. The floor displacement outlet is supplied with a distributor basket **2** for even air supply. There are different types to choose from (Figure 2):

- 'Standard type', with throttle device: VSD (without throttle device: VS)
- 'Short type', for raised floors with lower plenums; without throttle device: VK
- 'Short type with fixed damper' for even supply air distribution when using DN 200 in assembly rooms or with low air outlet volume flow rates: VL
- 'Low type', with openable basket bottom to enable additional air supply from below, best for raised floors with thicker tiles and lower plenums, with throttle device: VND (without throttle device: VN)
- 'Perforated sheet metal type' for metal floor air outlets, with throttle device: VPD

When the floor plan is altered the floor tiles with air outlets can be easily exchanged for tiles without air outlets. The local air supply to the room can therefore be increased or reduced as required. The supply air is fed to the floor displacement outlet via the distributor basket. The space under the raised floor acts as a pressurized plenum. The floor displacement outlet can also be connected to the supply air ductwork via a rectangular connection box **7** with flexible duct.



Figure 2: Various types of distributor basket

Table 1: Technical data

Air outlet volume flow rate \dot{V}_A :	≤ 28 l/s [100 m ³ /h]
Nominal ϕ = Installation ϕ :	DN 200
Supply air temperature ϑ_{su} :	≥ 20 °C
Temperature difference between	
– supply air and indoor air ²⁾ $\Delta\vartheta$:	-1 to -4 K
– supply air and return air ³⁾ $\Delta\vartheta$:	≤ -7 K
Coverage radius of a floor displacement outlet:	4 – 5 m
Weight of air outlet:	0.8 kg
Breaking load ⁴⁾ of air outlet element:	14.7 kN

¹⁾ For the required air outlet type (kind, material, etc.) or possible combination of individual components, see Table 3 'Types available' on page 6

²⁾ At head height of a seated person

³⁾ For room heights up to approx. 3 m; otherwise higher $\Delta\vartheta$ possible

⁴⁾ Load class to EN 13264: 'Heavy'; point load applied centrally with steel cube, edge length 25 x 25 mm with corner radius min. 2 mm

⁵⁾ The slide **8b** is adjustable from the room

Key for all pages:

- | | | |
|-----------------------------|----------------------------|---------------------------------------|
| 1 Air outlet element | 5 Clamp insert | 8a \dot{V} damper (optional) |
| 1a Air slots | 5b Claw fastener | 8b Slide ⁵⁾ |
| 1b Air outlet centre | 5d Clamp collar | 9 Floor tile |
| 2 Distributor basket | 6 Protective collar | 9a Through bore |
| 3 Throttle device | 7 Connection box | 9b Stepped bore |
| 4 Seal (by others) | 8 Connection spigot | |

Floor displacement outlet

Installation options and dimensions

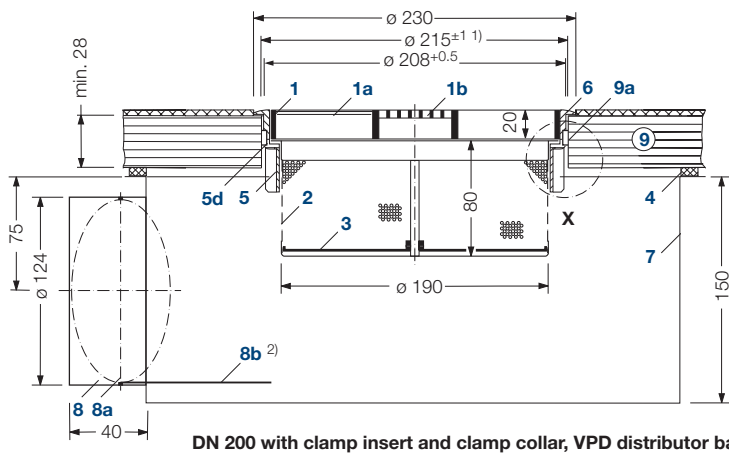

DN 200 with clamp insert and clamp collar, VPD distributor basket

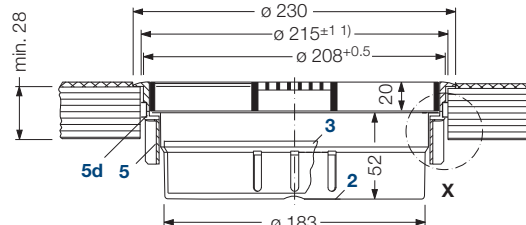

DN 200 with clamp insert and clamp collar, VND distributor basket

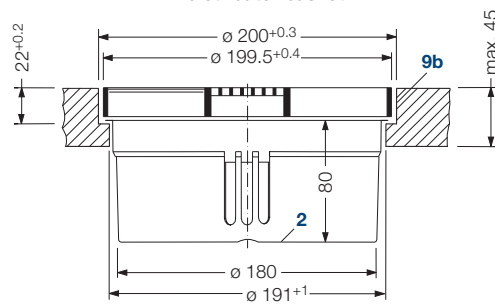

DN 200 installation in stepped bore, VK distributor basket

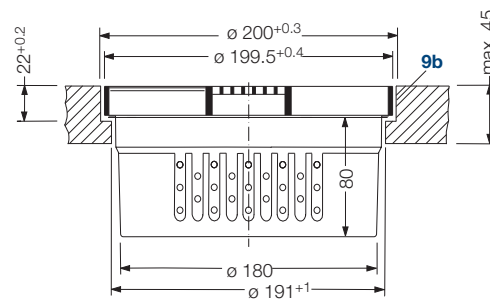

DN 200 installation in stepped bore, distributor basket VL

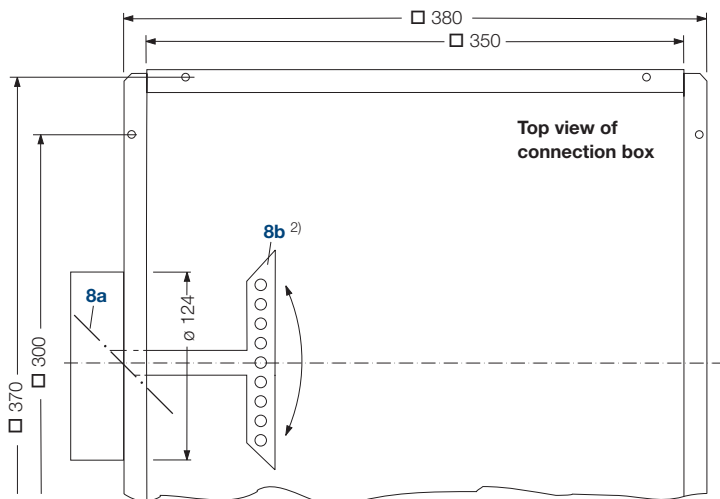

Top view of connection box

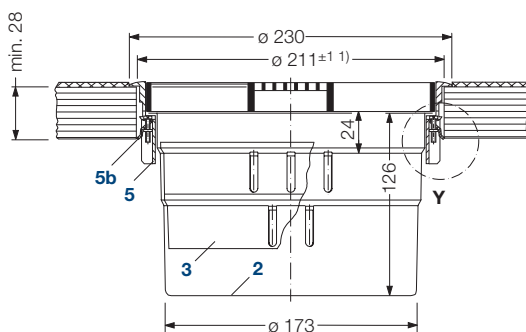

DN 200 with clamp insert and claw fastener, VSD distributor basket

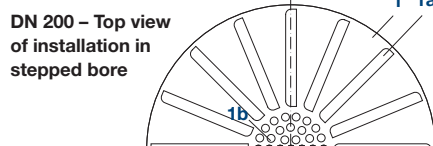

DN 200 - Top view of installation in stepped bore

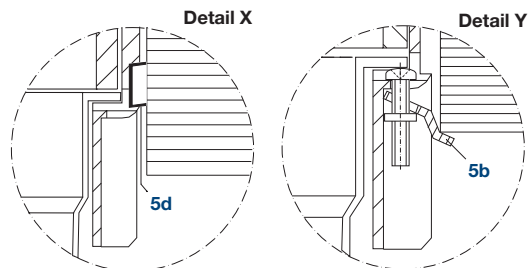

Detail X

Detail Y

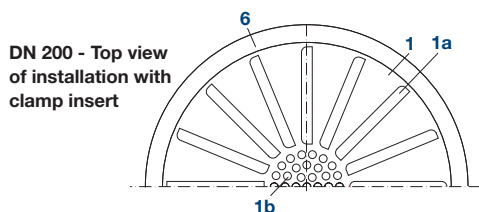

DN 200 - Top view of installation with clamp insert

Notes:

Any distributor basket can be used for the respective installation options. Likewise connection box 7 can be used for the air outlet placement in the other figures.

1) $\varnothing 211^{+1}$ for fastening with claw fastener,
 $\varnothing 215^{+1}$ for fastening with clamp collar

2) The slide 8b is adjustable from the room

Floor displacement outlet

Mode of operation

Mode of operation

The supply air flows into the distributor basket and then through the radial air slots and the perforated air outlet centre into the room. The special shape of the slots deflects the air jets which slide along the floor (Figure 3). The result is a low-turbulence horizontal, radial supply air flow at low velocity.

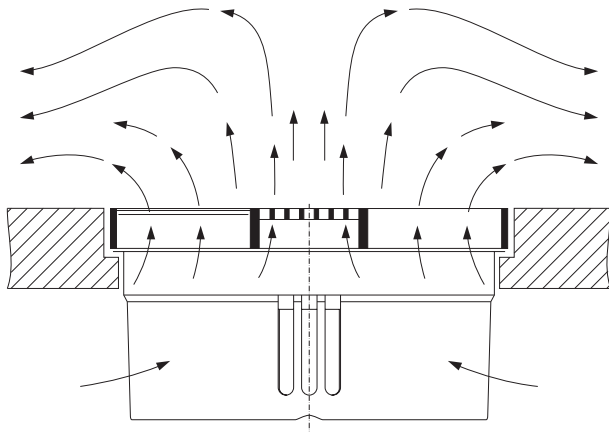

Figure 3: Floor displacement outlet, jet pattern



Figure 4: Low-turbulence horizontal, radial jet dispersion, made visible with smoke tracer

Figure 5 shows the air velocities measured in the near-zone of the air outlet for two air volume flow rates. Already at an approximate distance of 0.5 m from the air outlet they are low and allowable indoor air velocities to EN ISO 7730 are not exceeded. Despite the low air velocities, we recommend a minimum spacing of 0.8 m between air outlet and next seat. This prevents the seat from obstructing jet dispersion and possibly resulting in impaired thermal comfort for the occupants.

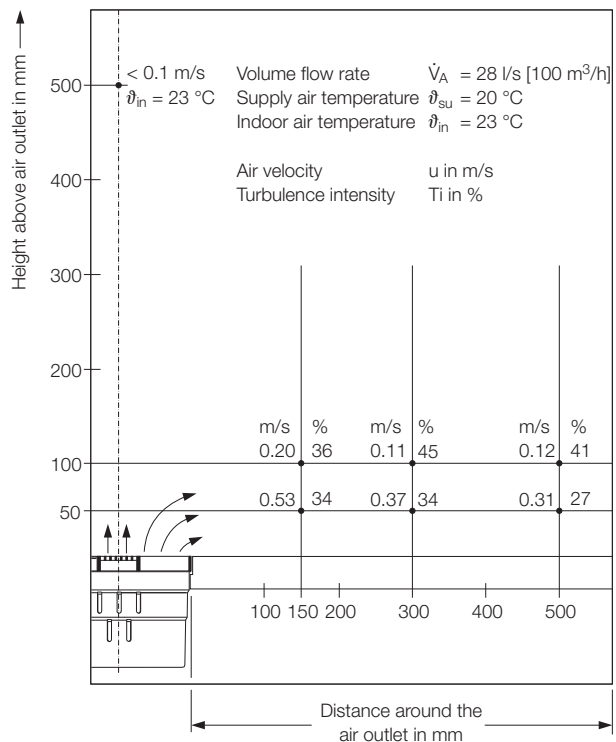
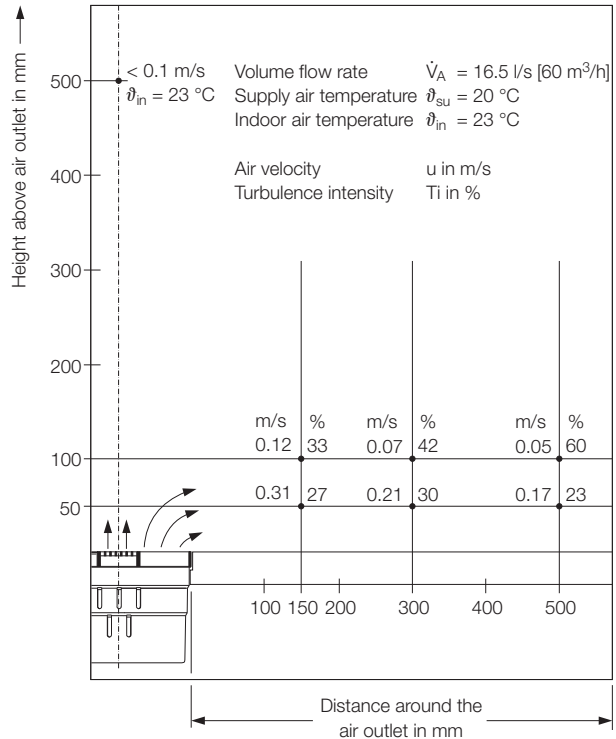
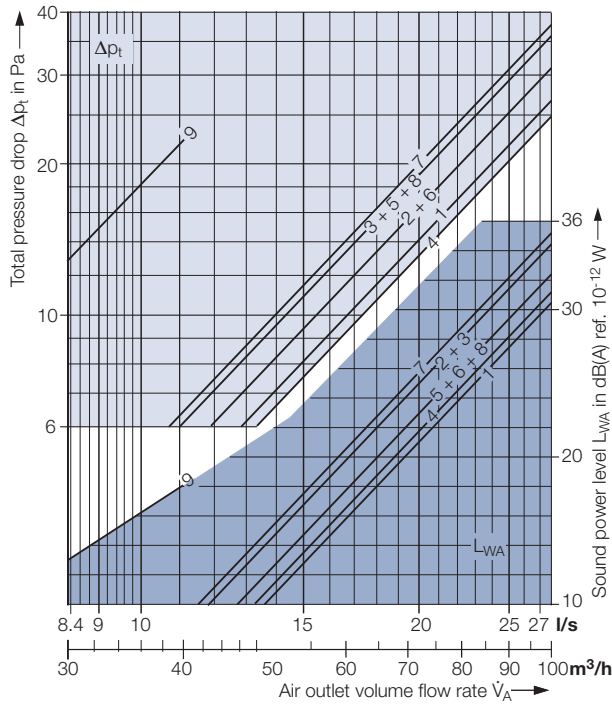

Figure 5: Air velocities above the floor with different air outlet volume flow rates \dot{V}_A
 Above: $\dot{V}_A = 16.5 \text{ l/s [60 m}^3\text{/h]}$
 Below: $\dot{V}_A = 28 \text{ l/s [100 m}^3\text{/h]}$

Floor displacement outlet

Sound power level and pressure drop

Sound power level and pressure drop ¹⁾



No.	Air outlet volume flow rate \dot{V}_A		Total pressure drop Δp_t Pa	Sound power level in dB ref. 10^{-12} W								
	l/s	m ³ /h		L_{WA} dB(A)	Octave band centre frequency in Hz							
					63	125	250	500	1 K	2 K	4 K	
1	16.5	60	10	16	24	21	20	14	10	—	—	
	22	80	17	24	32	29	28	22	18	—	—	
	28	100	27	30	38	36	34	28	24	12	—	
2	16.5	60	11	20	26	26	25	18	12	—	—	
	22	80	20	28	34	34	33	26	20	—	—	
	28	100	31	34	40	40	39	32	26	14	—	
3	16.5	60	13	20	26	27	25	17	12	—	—	
	22	80	23	28	34	35	33	25	20	—	—	
	28	100	36	34	40	41	39	31	26	12	—	
4	16.5	60	9	17	25	22	20	14	12	—	—	
	22	80	16	25	33	30	28	22	20	—	—	
	28	100	25	31	39	36	34	28	26	12	—	
5	16.5	60	13	18	25	22	20	15	14	—	—	
	22	80	23	26	33	30	28	23	22	12	—	
	28	100	36	32	39	36	34	29	28	18	—	
6	16.5	60	11	18	23	23	23	15	12	—	—	
	22	80	20	26	31	31	31	23	20	—	—	
	28	100	31	32	37	37	37	29	26	12	—	
7	16.5	60	14	21	23	24	25	17	17	—	—	
	22	80	25	29	31	32	33	25	25	14	—	
	28	100	37	36	38	39	40	32	32	21	—	
8	16.5	60	13	18	21	23	23	15	12	—	—	
	22	80	23	26	29	31	31	23	20	—	—	
	28	100	36	32	35	37	37	29	26	11	—	
9	8.5	30	13	13	36	18	15	—	—	—	—	
	10	35	18	16	36	21	19	9	9	—	—	
	11	40	23	18	37	24	22	13	13	—	—	

Size	Insertion loss in dB							Mean value
	Octave band centre frequency in Hz							
	125	250	500	1 K	2 K	4 K	8 K	
DN 200	18	12	7	4	6	7	3	8
DN 200	15	12	10	4	4	7	4	8

Table 2: Key to graphs

No.	Size	Type	Distributor basket		\dot{V} damper in connection spigot Damper angle α
			Throttle device ²⁾ % open	Aperture width / Disc lift mm	
1	DN 200	VSD	100	8	— ³⁾
2			100	8	90° open
3			100	8	45°
4	DN 200	VPD	100	45.0	— ³⁾
5			50	22.5	— ³⁾
6			100	45.0	90° open
7			50	22.5	90° open
8			100	45.0	45°
9	DN 200	VL	without throttle device		— ³⁾

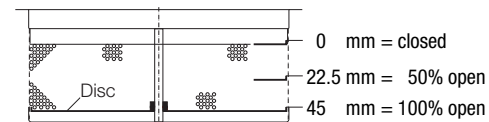
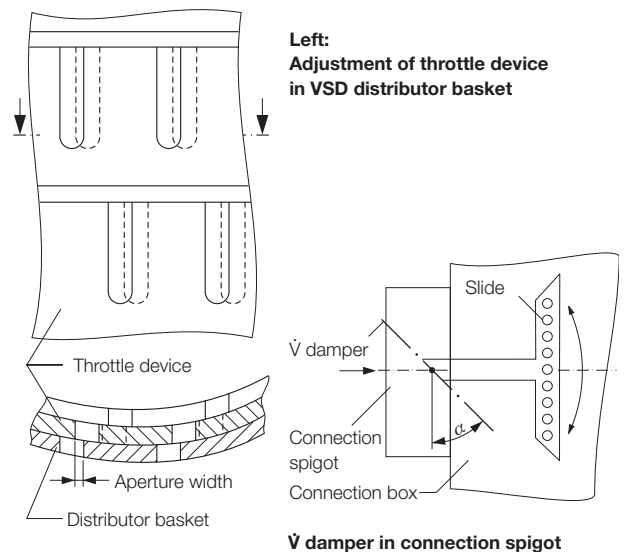

Adjustment of throttle device (disc) in VPD distributor basket

Figure 6: Adjustment of throttle device

¹⁾ The sound power level and pressure drop pertain to the use of the VSD and VPD distributor baskets. When the VK and VND distributor baskets are used, the values approximate those for the VSD type or remain within the permissible measuring tolerances.

²⁾ The throttle devices in the distributor baskets enable continuous volume flow reduction, preferably up to 50%, as well as full shut-off

³⁾ Without connection box

Without connection box With connection box

Floor displacement outlet

Types available, features

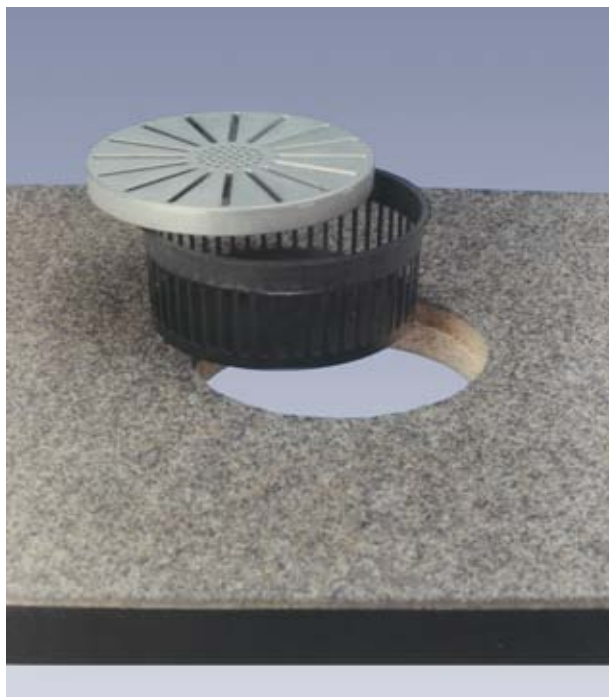

Figure 6: Floor displacement outlet Q-B-DN 200
Installation example: short distributor basket VK and floor tile with stepped bore

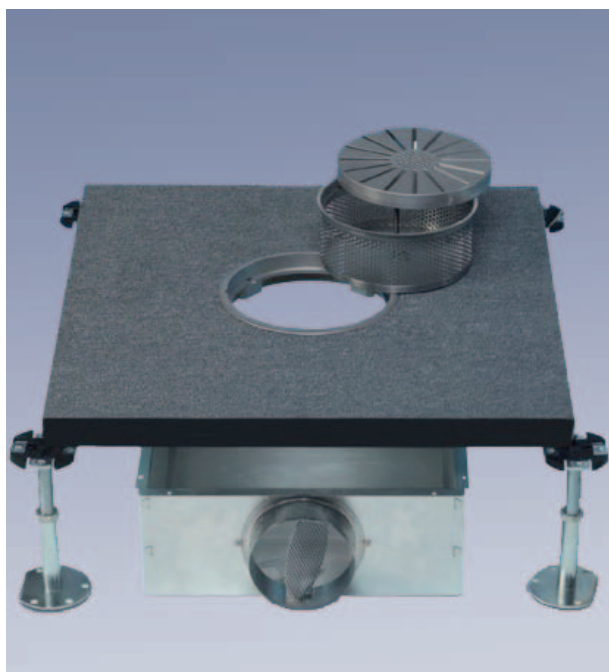

Figure 7: Floor displacement outlet Q-B-DN 200
Installation example: perforated sheet metal distributor basket VPD with throttle device and floor tile with clamp insert in a through bore; below it, connection box for duct connection

Table 3: Types available

Floor displacement outlet Component	Materials ¹⁾		
	PC	Al	St
Air outlet element DN 200		•	
For installation in through bore:			
Clamp insert			
– with clamp collar SR		• ³⁾	
– with claw fastener SK		• ³⁾	
For installation in through bore and stepped bore:			
Distributor basket			
– Standard type VS	•		
– with throttle device VSD	•		
– Short type VK	•		
– Short type with fixed damper VL	•		
– Low type VN	•		
– with throttle device VND	•		
– Perforated sheet metal type with throttle device VPD			•
Connection box			
– without V damper in connection spigot			•
– with V damper in connection spigot ²⁾			•

• = available

Features

- Suitable for displacement ventilation in commercial application
- Installation in conventional raised floor systems
- Air supply direct from the pressurized plenum or via connection box with flexible duct
- Low-turbulence horizontal, radial jet dispersion over the floor
- For air volume flow rates up to 28 l/s [100 m³/h]
- Coverage radius of 4 to 5 m
- Temperature difference between:
supply air and indoor air –1 to –4 K
supply air and return air ≤ –7 K ⁴⁾
depending on heat load and room height
- Floor installation by insertion in a stepped bore or installation with clamp insert in a through bore of a floor tile
- Fastening of clamp insert to floor tile with clamp collar or claw fastener
- Air outlet element and clamp insert made of aluminium, connection box made of galvanized sheet metal
- Air outlet element can be optionally locked against unauthorized removal
- Distributor baskets made of polycarbonate or galvanized sheet metal, with or without throttle or shutoff device
- Can be walked over, driven over and can support a wheelchair

¹⁾ PC = polycarbonate; Al = aluminium; St = galvanized sheet metal

²⁾ V damper not needed for distributor basket with throttle device

³⁾ Lock is optional

⁴⁾ For room heights up to approx. 3 m; otherwise higher $\Delta\vartheta$ possible

Floor displacement outlet

Type code and tender text

Type code

Q-B - DN 200 - _ _ - _ - _



Distributor basket

- VS = standard type
- VK = short type
- VL = short type with fixed damper
- VN = low type
- VP = perforated sheet metal type

Damper (only for distributor baskets VS, VN and VP)

- O = no volume flow damper
- D = with throttle device

Clamp insert

- SO = no clamp insert
- SK = claw fastener
- SR = clamp collar

Connection type

- P = floor plenum
- K = connection box

Tender text ¹⁾

..... units

Floor displacement outlet for low-turbulence horizontal, radial supply air flow above the floor, for installation in floor tiles of conventional raised floor systems;

the air outlet can be walked over, driven over and can support a wheelchair; load class to EN 13264: 'Heavy';

consisting of:

- circular air outlet element with radial air slots and perforated air outlet centre,
- distributor basket in the following options:
 - 'Standard type' with surrounding slots in basket casing, optionally fitted with throttle device for full shutoff of air outlet.
 - 'Short type' with surrounding slots in basket casing, best for low raised floors, without throttle device.
 - 'Short type with fixed damper' for even supply air distribution when used in assembly rooms or with low air outlet volume flow rates.
 - 'Low type' with surrounding slots in basket casing and openable bottom, best for raised floors with thicker tiles and lower plenums, optionally fitted with throttle device.
 - 'Perforated sheet metal type', for floor air outlets made of metal, including throttle device.
- optional clamp insert for installation in through bore of floor tile, fixed with clamp collar or claw fastener.
- optional connection box for direct connection of air outlet to a flexible duct, optionally fitted with volume flow damper adjustable from room.

The air outlet element can be optionally locked against unauthorized removal.

Material:

- Air outlet element made of aluminium in natural colour ²⁾
- Clamp insert made of aluminium in natural colour ²⁾
- Distributor basket made of galvanized sheet metal or polycarbonate
- Connection box made of galvanized sheet metal

Make:

Krantz

Type:

Q-B - DN 200 - _ _ - _ - _

Subject to technical alterations.

¹⁾ For the required air outlet type (kind, material, etc.) or possible combination of individual components, see Table 3 'Types available' on page 6

²⁾ Powder coating to RAL on request

Krantz GmbH

Uersfeld 24, 52072 Aachen, Germany

Phone: +49 241 441-1

Fax: +49 241 441-555

info@krantz.de | www.krantz.de

The logo for Krantz GmbH, featuring the word "Krantz" in a stylized, blue, cursive script font.