

**Krantz**

Adjustable induction outlet IN-V

**Air & Climate Solutions**

# Adjustable induction outlet

## Construction and function

### Preliminary remarks

In addition to its induction outlet with preset discharge direction <sup>1)</sup>, Krantz also provides the **adjustable** induction outlet in two types:

#### IN-V2

- Element width 28 mm
- Discharge height 2.7 m to 5 m
- 1-row, 2-row, 3-row and 4-row design

#### IN-V3

- Element width 15 mm
- Discharge height 2.5 m to 3.5 m
- 1-row design

Thanks to its small width, type IN-V3 is eminently suited for commercial rooms requiring unobtrusive air distribution systems in the ceiling.

### Construction and function

The linear discharge element **2**, which is set inside the air outlet profile **1**, consists of a number of consecutive, rotatable single elements, each with two jet channels **3**. As the air flows through the jet channels, many single high-stability and high-induction jets form; this results in a rapid drop in jet velocity and fast equalization of supply air temperature and room temperature.

Rotating the cylindrical single elements alters the incline of the jet channels and adjusts the jet direction from horizontal to vertical.

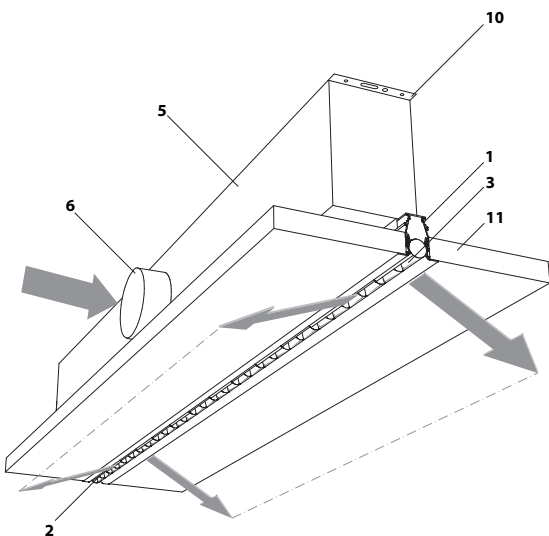

Fig. 1: IN-V2 and IN-V3, 1-row design

This enables to spread the total jet as broadly as required.

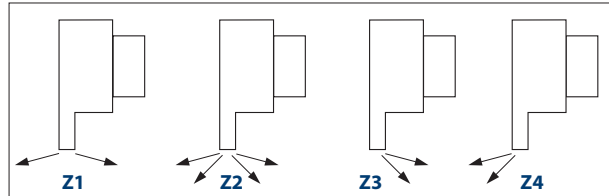

Fig. 2: Variable jet direction for total jet spread as required;  
Z1, Z2 = two-sided discharge, Z3, Z4 = one-sided discharge

The air outlet volume flow rate can thus be delivered as required to the right or to the left in line with the setting of the single elements. Also, the entire supply air can be discharged on one side only (see Fig. 2-Z3 and Z4). The single elements can be closed by turning beyond the horizontal jet direction (see page 3). The adjustable induction outlet is preset as in Fig. 2-Z2. If another setting (Z1, Z3 or Z4) is required, the client must state it when ordering.

The adjustable induction outlet generates a diffuse indoor air flow with intensive, draught-free flushing of the occupied zone. Allowable indoor air velocities to EN 13779 are easily met (For layout see pages 8 ff).

For both outlet types, blank elements (without connection boxes) are available where continuous lines of outlets are required, and corner pieces where the air outlets are to be arranged at right angles to each other. If required, the diffuser element can be subsequently mounted from the room, e.g. in plasterboard ceilings, using an additional screw connection.

Optionally, the adjustable induction outlet can also be used as a return air inlet.

#### Volume flow rates and max. temperature difference

Induction outlet	IN-V2	IN-V3
Volume flow rate	$m^3/(h \cdot m)$	$m^3/(h \cdot m)$
	40 – 400	10 – 60
Max. temperature difference $\Delta\vartheta$ between supply air and indoor air	-10 K when cooling + 6 K when heating	

# Adjustable induction outlet

## Connection and discharge direction

### Connection

The outlet connection to the air ductwork is done via a connection box **5** which, for higher insertion loss, is optionally available with acoustic lining. At the side of the connection box is a spigot **6** for connection to a circular duct; this spigot can be optionally fitted with a volume flow damper **7** which will be adjustable from the room (see page 6).

The spigot can be supplied with or without seal, as required.

### Standard setting of discharge direction

When used for supply air, the outlet is supplied with a preset discharge angle of 0 – 40°, which ensures a broad spread of the total supply air jet. This angle may vary a little depending on the temperature difference and the structure of the ceiling surface.

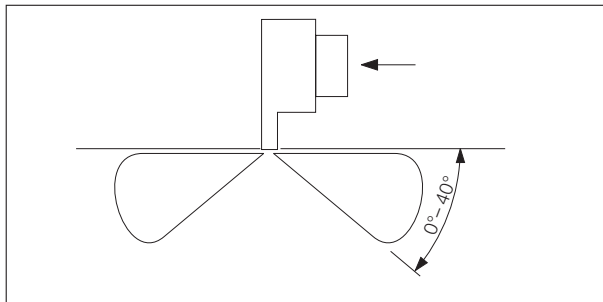

Fig. 3: Standard setting of discharge direction



Ausblaswinkel  
Z1  
ca. 0 – 20°



Z2  
ca. 0 – 40°  
(Standard)

Fig. 4: Air jet pattern made visible with smoke tracer

### Setting of air discharge elements

The single elements inside the outlet profile are preset at the factory; those of type IN-V2 are also protected against unintentional alteration of setting. Resetting can be easily done on site using a key, as is shown below.

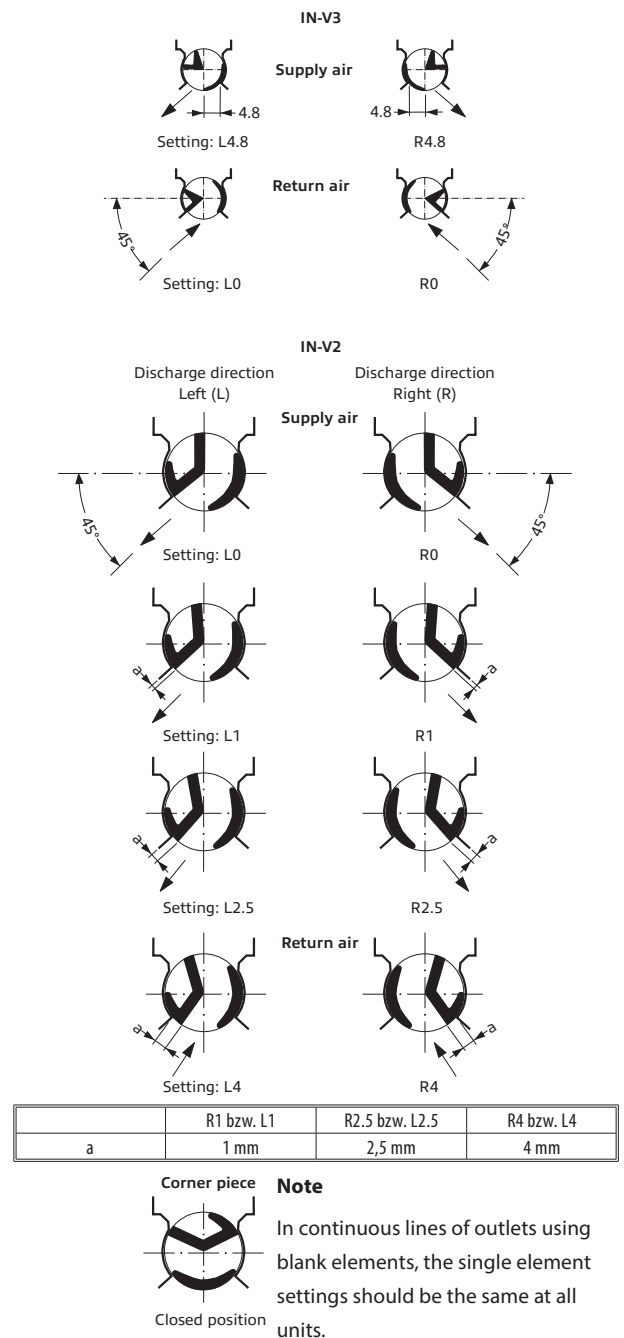
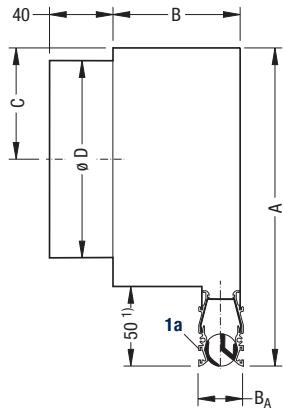

Fig. 5: IN-V2 and IN-V3; examples of settings of jet direction from horizontal to vertical, as well as closed position

# Adjustable induction outlet

## Construction design of IN-V2

**IN-V2 with flush contact profile 1a** for false ceiling; connection box **without** acoustic lining



**IN-V2 with fixed support profile 1b**; connection box **with** acoustic lining and volume flow damper

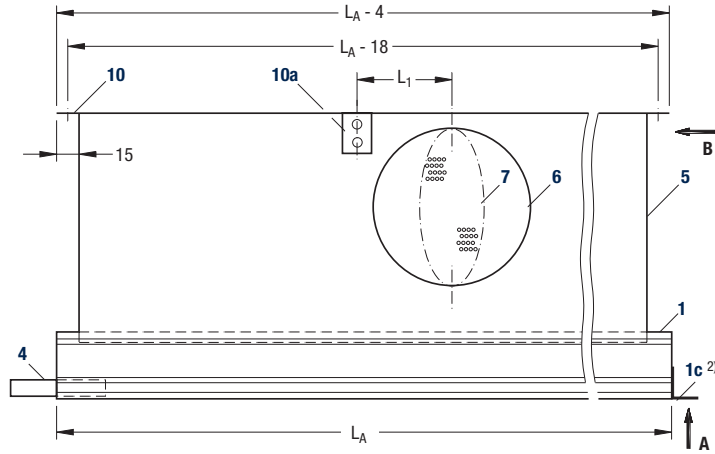
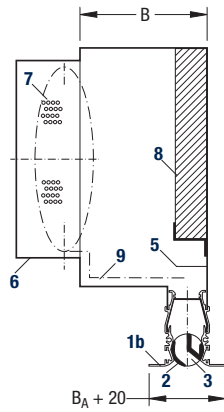

**Flush contact profile**  
(e.g. for metal ceilings)

**Ceiling support profile**  
(e.g. for plasterboard ceilings)

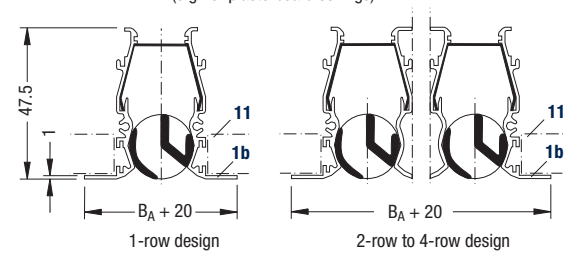
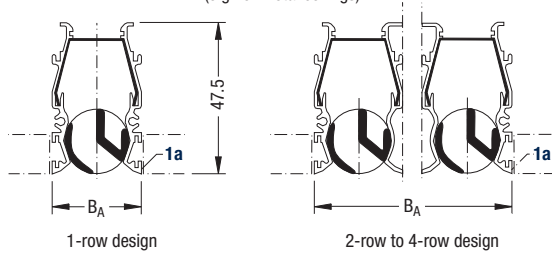

**Caption**

- 1 Air outlet profile
- 1a Flush contact profile
- 1b Ceiling support profile
- 1c Endwise angle piece
- 2 Air discharge element
- 3 Jet channel
- 4 Alignment piece
- 5 Connection box
- 6 Connection spigot
- 7 Volume flow damper
- 8 Acoustic lining
- 9 Adjusting device
- 10 Suspension bracket
- 11 False ceiling
- 12 Bore for suspension
- 13a Quick fastener (by others)
- 13b Threaded rod (by others)

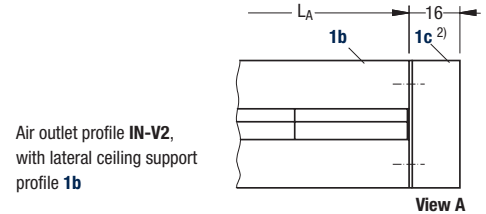

Air outlet profile **IN-V2**, with lateral ceiling support profile **1b**

Type	Design	Length LA <sup>1)</sup> mm	Air outlet				Connection box <sup>3)</sup>						
			Volume flow rate VA l/(s·m)	m <sup>3</sup> /(h·m)	Discharge height m	BA mm	A mm	C mm	D mm	L <sub>1</sub> mm	B mm	G <sup>4)</sup> kg	LE mm
IN-V2	1-row	1 050	11 – 36	40 – 130	2,7 – 4	28	175	62,5	99	100	100	4,9	123
		1 200					6,1						
		1 350					6,8						
	2-row	1 050	19 – 67	70 – 240	2,7 – 4,5	56	235	92,5	159	130	130	7,1	151
		1 200					8,5						
		1 350					9,5						
		1 500					10,5						
	3-row	1 050	33 – 89	120 – 320	3,0 – 5	84	255	102,5	179	140	160	8,7	179
		1 200					10,2						
		1 350					11,4						
	4-row	1 050	44 – 111	160 – 400	3,5 – 5	112	275	112,5	199	150	190	12,6	207
		1 200					10,2						
		1 350					12,1						
		1 500					13,5						

<sup>1)</sup> Other lengths and greater heights on request; for IN-V2: length LA = number of single elements x 75

<sup>2)</sup> Accessories: endwise angle pieces 1c for IN-V2, supplied loose, with fastening screws

<sup>3)</sup> Connection box with 2 or more spigots on request

<sup>4)</sup> Weights stated for design with acoustic lining; without acoustic lining the values are reduced by approx. 0.2 kg

# Adjustable induction outlet

## Construction design of IN-V3 and suspension

IN-V3 with flush contact profile 1a for false ceiling; connection box **without** acoustic lining

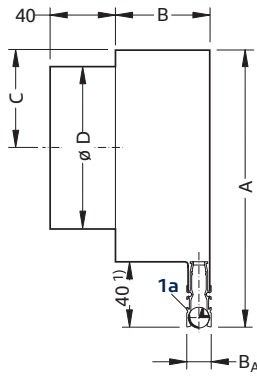

IN-V3 with fixed support profile 1b; connection box **with** acoustic lining and volume flow damper

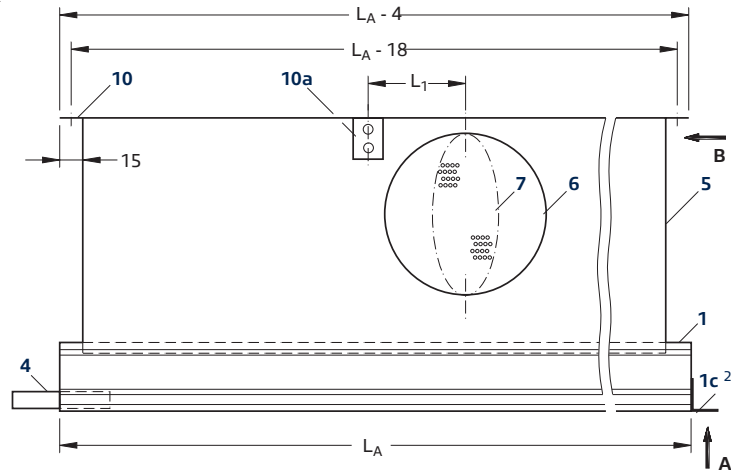
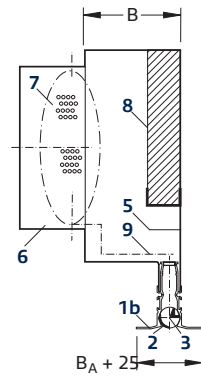

**Flush contact profile (flangeless - type A)**  
(e.g. for metal ceilings)

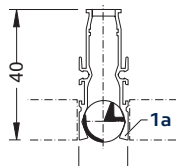

**Ceiling support profile (flanged - type D)**  
(e.g. for plasterboard ceilings)

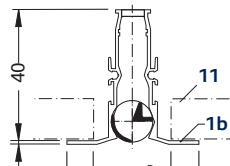

Air outlet profile IN-V3, with lateral ceiling support profile 1b

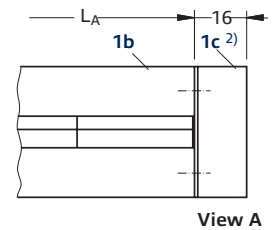

### Caption

- 1 Air outlet profile
- 1a Flush contact profile
- 1b Ceiling support profile
- 1c Endwise angle piece
- 2 Air discharge element
- 3 Jet channel
- 4 Alignment piece
- 5 Connection box
- 6 Connection spigot
- 7 Volume flow damper
- 8 Acoustic lining
- 9 Adjusting device
- 10 Suspension bracket
- 11 False ceiling
- 12 Bore for suspension
- 13a Quick fastener (by others)
- 13b Threaded rod (by others)

Type	Design	Length L <sub>A</sub> <sup>1)</sup> mm	Air outlet				Connection box <sup>3)</sup>						L <sub>E</sub> mm
			Volume flow rate V <sub>A</sub> l/(s·m) m <sup>3</sup> /(h·m)	Discharge height m	B <sub>A</sub> mm	A mm	C mm	D mm	L <sub>1</sub> mm	B mm	G <sup>4)</sup> kg		
IN-V3	1-row	1 050	3 - 17	10 - 60	2,5 - 3,5	15	170	65	99	90	80	4,3	110
		1 200										4,9	
		1 350										5,5	
		1 500										6,1	

<sup>1)</sup> Other lengths and greater heights on request; for IN-V3: length L<sub>A</sub> = number of single elements x 75

<sup>2)</sup> Accessories: endwise angle pieces 1c for IN-V3, supplied loose, with fastening screws

<sup>3)</sup> Connection box with 2 or more spigots on request

<sup>4)</sup> Weights stated for design with acoustic lining; without acoustic lining the values are reduced by approx. 0.2 kg

# Adjustable induction outlet

## Installation of the IN-V2 from the room

### Installation of the IN-V2 from the room <sup>1)</sup>

For IN-V2 installation from the room, the diffuser elements and the connection boxes are supplied separately. Fig. 6a shows the "shaft system" (ceiling support profile) for plasterboard ceilings. In this case the connection boxes are mounted prior to the installation of the suspended ceiling and connected to the air ductwork.

The diffuser elements are installed only upon completion of the room ceiling. Fig. 6b shows the "push-in system" (flush contact profile) for metal ceilings. Expansion brackets for blank elements <sup>2)</sup> are used for metal or plasterboard ceilings, see Fig. 6c

<sup>1)</sup> Solution for IN-V3 on request

<sup>2)</sup> Also for IN-V3

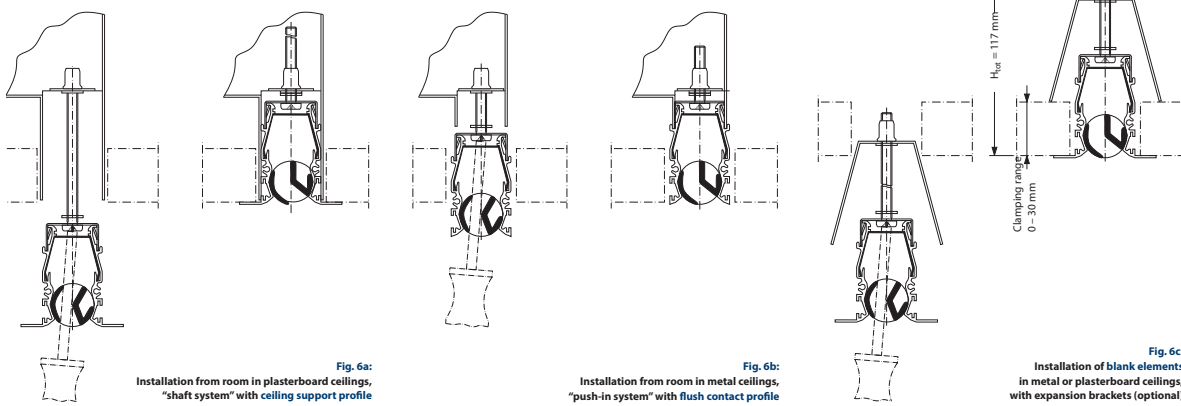

Fig. 6: Different systems for IN-V2 installation from the room

## Suspension

For suspension from the ceiling the induction outlet is fitted with endwise suspension brackets **12**. The suspension brackets are suitable for quick fastener or threaded rods.

Quick release skewers or threaded rods are not included.

### Suspension examples

**View B**  
Suspension with threaded rod M8 and lock nuts

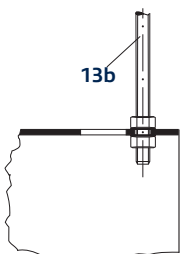

**View B**  
Suspension with quick fastener

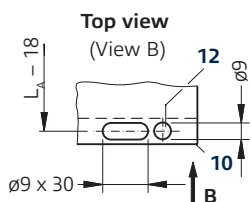
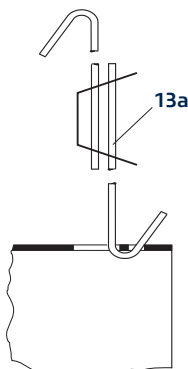

**Caption**

- 10** Suspension bracket
- 12** Bore for suspension
- 13a** Quick fastener (by others)
- 13b** Threaded rod (by others)

### Blank element with standard quick fastener (by others)

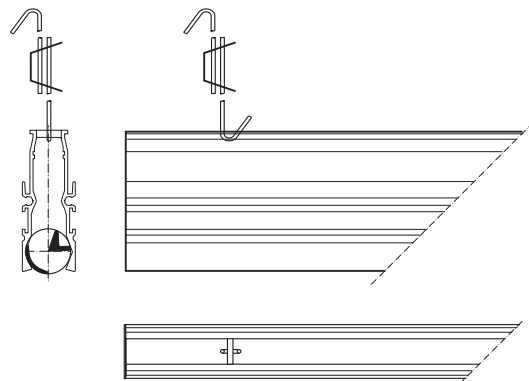

# Adjustable induction outlet

## Corner pieces and adjustment of volume flow damper (IN-V2 and IN-V3)

### Corner pieces

For arranging air outlets at right angles to each other, e.g. for getting square or rectangular areas, corner pieces are available as accessories for IN-V2 in the 1-row to 4-row design and for IN-V3 in the 1-row design. The single elements are in closed position (see page 3).

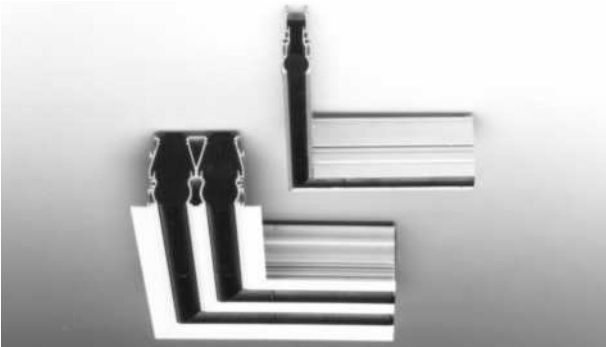

Fig. 7: Corner pieces for IN-V2, 2-row design, with lateral ceiling support profile (bottom) and for IN-V3 with flush contact profile (top)

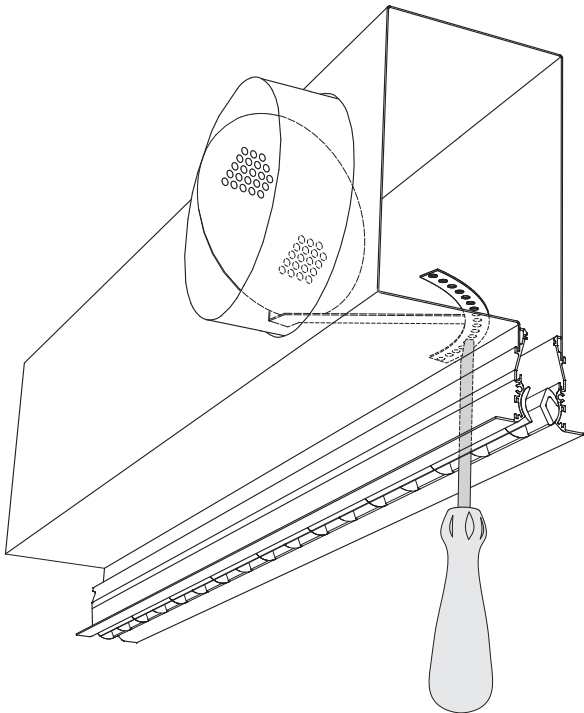

Fig. 9: Adjustment of volume flow damper from below at perforated slide (perforation  $\varnothing$  4 mm) using a rod, e.g. a screwdriver

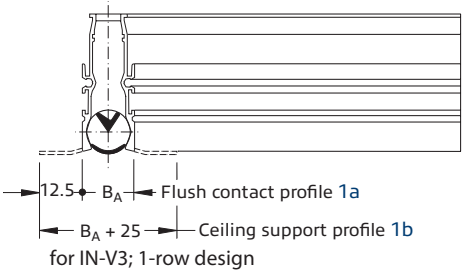
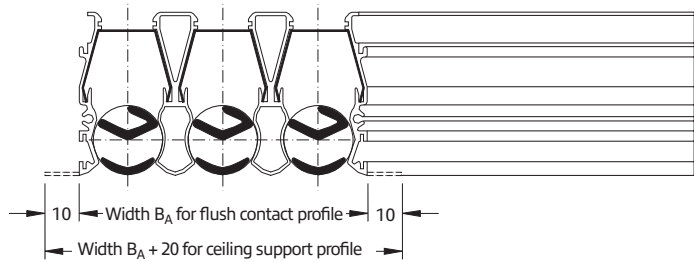
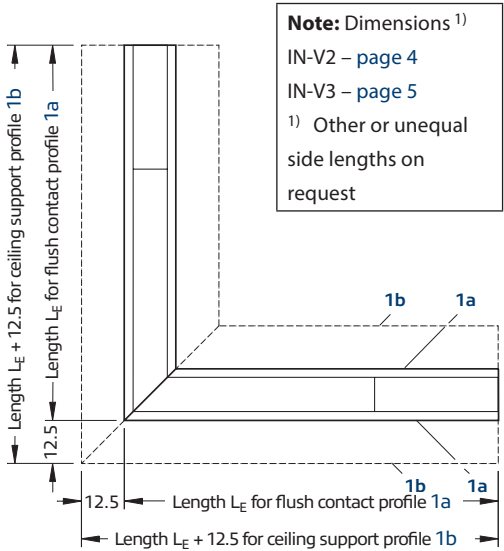
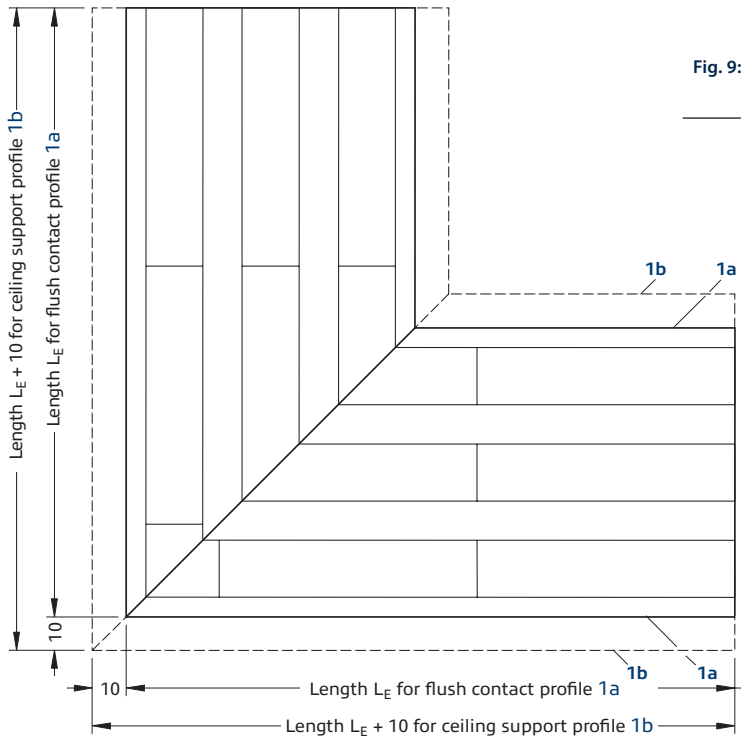

Fig. 8: Sketches of corner pieces for IN-V2; 1-row to 4-row design (3-row design shown here)



# Adjustable induction outlet

## Layout sheet

### Comfort criteria <sup>1)</sup>

The outlet layout must comply with the maximum allowable indoor air velocities  $u$  in the occupied zone in the cooling mode. The indoor air velocity depends on the cooling load that is to be removed from the room. The maximum specific cooling capacity  $q$  depends on the discharge height and the maximum allowable indoor air velocity  $u$  (Graph 1).

Graph 1 enables to determine for the cooling mode the maximum specific volume flow rate  $V_{sp\ max}$  in relation to the maximum specific cooling capacity and the maximum temperature difference  $\Delta\theta_{max}$ . The volume flow rate supplied to the room  $V_{sp\ act}$  may not exceed this value.

Graph 2 enables to determine the minimum centre spacing between two outlet rows on the basis of the maximum specific volume flow rate.

<sup>1)</sup> See our brochure ref. TB 69 'Layout specifications for thermal comfort'

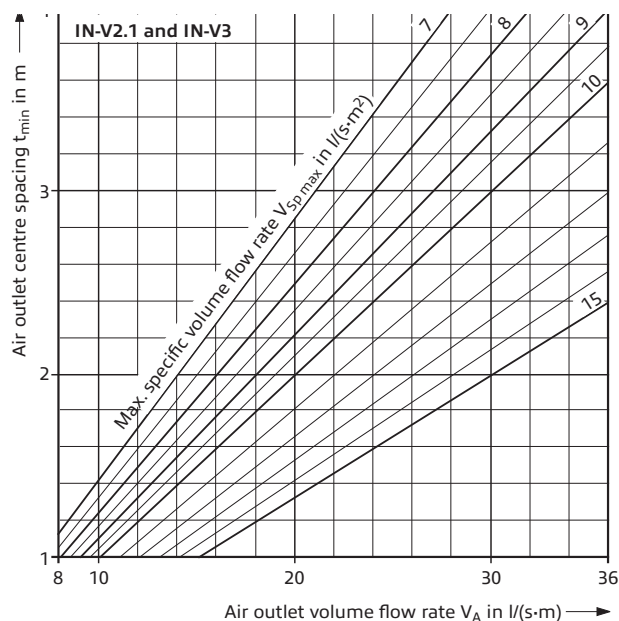
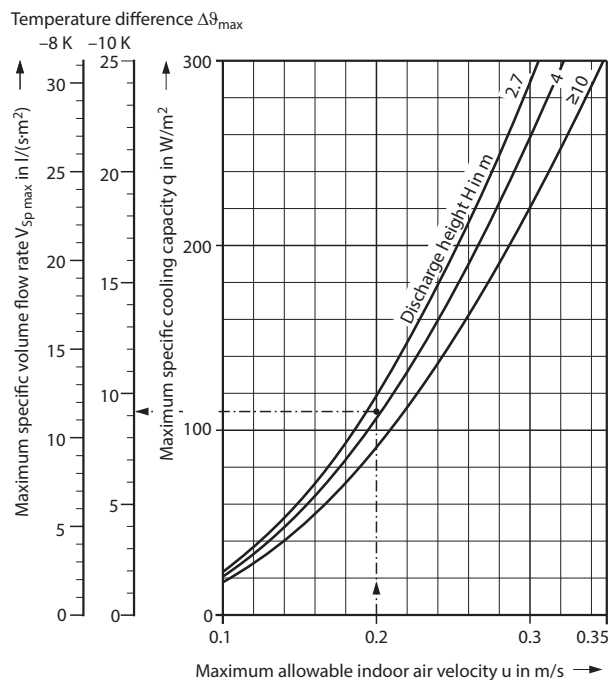

Graph 1: Max. specific volume flow rate

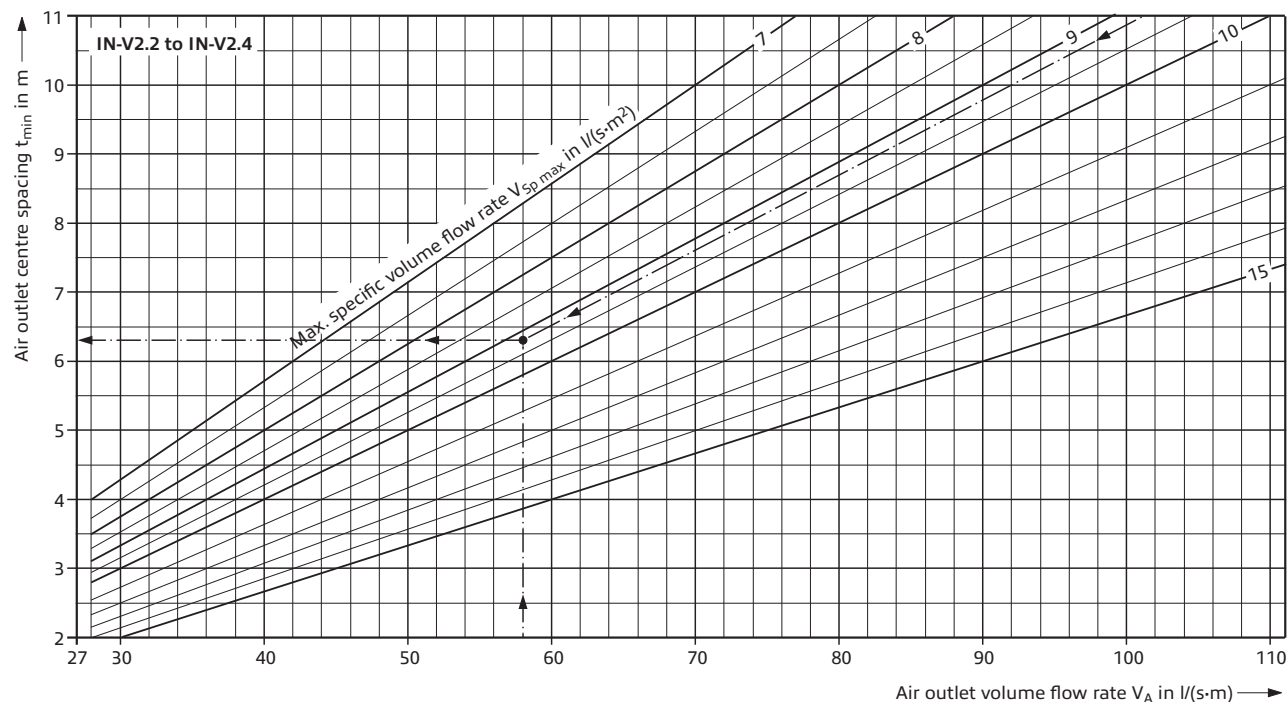

Graph 2: Minimum centre spacing between two outlet rows



# Adjustable induction outlet

## Layout as supply air outlet

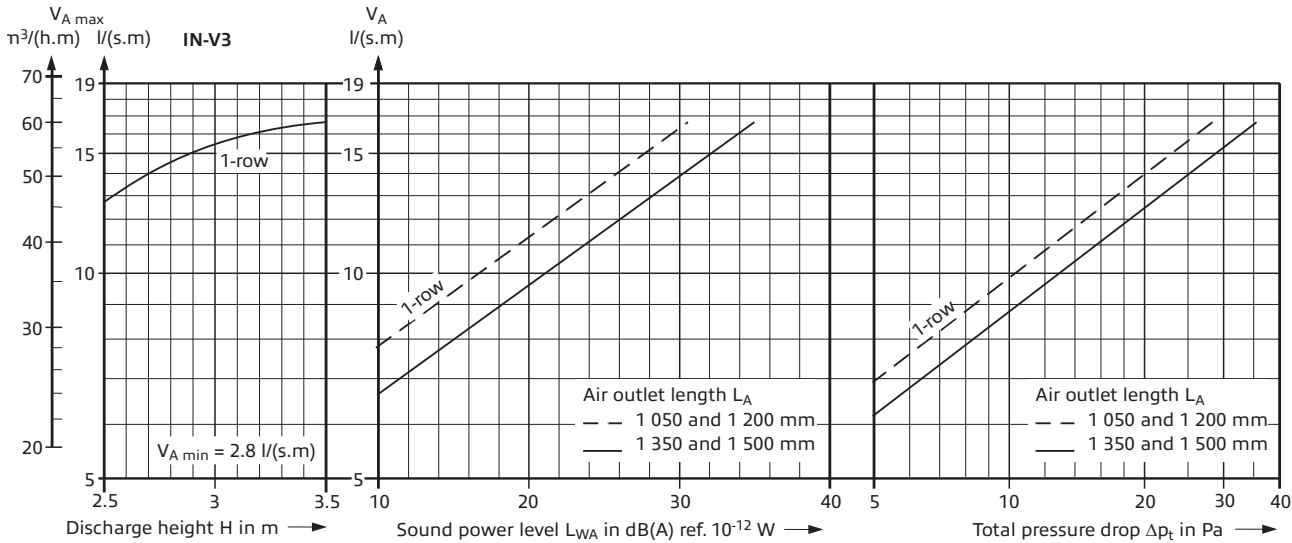
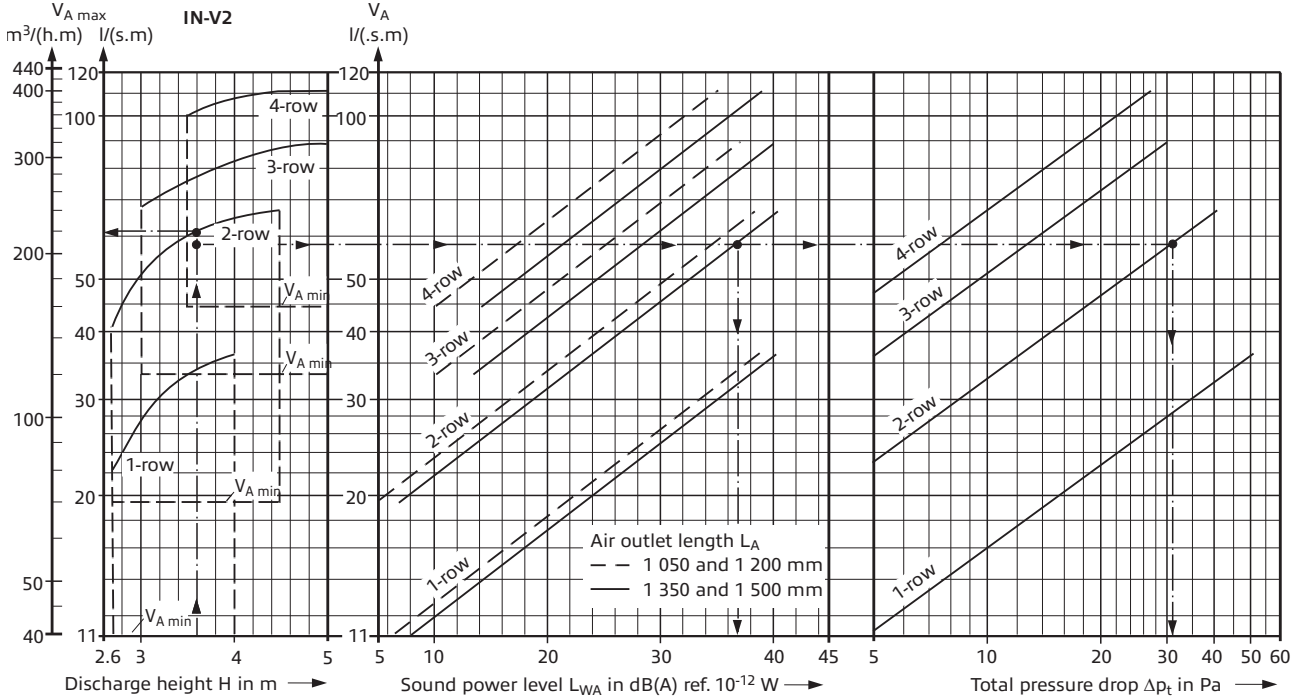

Layout example	
Induction outlet	<b>IN-V2</b>
1 Length / Design	1 350 / 2-row
2 Supply air volume flow rate $V$	6 945 l/s
3 Discharge height $H$	3,6 m
4 Room area $A$	1 000 m <sup>2</sup>
5 Max. allowable sound power level $L_{WA}$	40 dB(A)
6 Comfort criteria (see page 8)	
- Max. allowable indoor air velocity $u$	0,2 m/s
- Max. specific volume flow rate $V_{Sp \max}$ at $\Delta\theta_{\max} = -10$ K [Graph 1 on page 8]	33 m <sup>3</sup> /(h·m <sup>2</sup> )
- Actual specific volume flow rate $V_{Sp \text{act}}$	25 m <sup>3</sup> /(h·m <sup>2</sup> )
Criterion is met if $V_{Sp \text{act}} < V_{Sp \max}$	
<b>From nomogramm:</b>	
7 $V_{A \max}$	62 l/(s·m)
8 $V_A$ selected	58 l/(s·m)
9 $Z_1$ [from 2 : 8]	120 m
10 $Z_2$ [from 9 : 1]	88 units
11 $L_{WA}$	≈ 37 dB(A)
12 $\Delta p_t$	≈ 32 Pa
13 $t_{\min}$ [Diagramm 2, Seite 8]	≈ 6,4 m

DThe graph values for sound power level and pressure drop apply to an induction outlet with connection box fitted with acoustic lining, discharge direction 0° to 40° as well as built-in volume flow damper in position "open". If the connection box is without acoustic lining, the sound power level is higher by 1 – 2 dB(A) ref. 10-12 W, but the pressure drop remains unchanged. If the volume flow damper is closed, the sound power level rises by 2 – 6 dB(A) ref. 10-12 W while the pressure drop doubles or even triples.

- Key for layout**
- $V_A$  = volume flow rate per metre of air outlet in l/(s·m)
  - $V_{A \max}$  = max. volume flow rate per metre of air outlet when cooling in l/(s·m)
  - $V_{A \min}$  = min. volume flow rate per metre of air outlet when cooling in l/(s·m)
  - $V_{Sp \max}$  = max. specific volume flow rate per m<sup>2</sup> of floor area in l/(s·m<sup>2</sup>)
  - $V_{Sp \text{act}}$  = actual specific volume flow rate per m<sup>2</sup> of floor area in l/(s·m<sup>2</sup>)
  - $u$  = max. allowable indoor air velocity in m/s
  - $q$  = max. specific cooling capacity in W/m<sup>2</sup>
  - $\Delta\theta_{\max}$  = max. temperature difference supply air to return air in K
  - $t_{\min}$  = minimum centre spacing between two outlet rows in m
  - $H$  = discharge height in m
  - $L_{WA}$  = sound power level in dB(A) ref. 10-12 W
  - $\Delta p_t$  = total pressure drop in Pa

# Adjustable induction outlet

## Sound power level – Supply air <sup>1)</sup>

### Sound power level and pressure drop

The adjustable induction outlet is quiet. For sound power level and insertion loss in relation to octave band centre frequency, see pages 10 – 12. The sound power level of the air outlet with lined connection box is lower by about 2 dB(A) ref. 10<sup>-12</sup> W and its insertion loss is much higher. The pressure drop is not changed by the lining.

	Air outlet volume flow rate		Total pressure drop $\Delta p_t$ Pa	Connection with acoustic lining									Total pressure drop $\Delta p_t$ Pa	Connection without acoustic lining								
	$V_A$ m <sup>3</sup> /(h·m)	l/(s·m)		Sound power level $L_W$ in dB										Sound power level $L_W$ in dB								
				$L_{WA}$ dB(A)	Octave band centre frequency in Hz						Octave band centre frequency in Hz			$L_{WA}$ dB(A)	Octave band centre frequency in Hz							
				125	250	500	1 K	2 K	4 K		125	250	500	1 K	2 K	4 K						
<b>IN-V2</b>																						
1-row design length in mm	1 050	60	16.5	11	17	25	22	16	—	—	—	11	19	25	24	18	—	—				
		90	25	24	28	34	32	27	18	11	—	24	30	34	34	29	20	15	—			
		120	33	42	36	40	39	35	29	23	14	43	38	40	41	36	31	27	17			
	1 200	60	16.5	11	17	25	22	16	—	—	—	11	19	25	24	18	—	—	—			
		90	25	24	28	34	32	27	18	11	—	24	30	34	34	29	20	15	—			
		120	33	42	36	40	39	35	29	23	14	43	38	40	41	36	31	27	17			
	1 350	60	16.5	11	19	25	22	19	—	—	—	11	20	25	23	21	—	—	—			
		90	25	24	30	34	33	30	20	13	—	24	31	35	34	31	22	15	—			
		120	33	42	38	41	41	37	31	26	16	43	39	42	42	38	32	27	17			
	1 500	60	16.5	11	19	25	22	19	—	—	—	11	20	25	23	21	—	—	—			
		90	25	24	30	34	33	30	20	13	—	24	31	35	34	31	22	15	—			
		120	33	42	38	41	41	37	31	26	16	43	39	42	42	38	32	27	17			
2-row design length in mm	1 050	120	33	10	19	28	23	18	—	—	10	20	28	24	18	10	—	—				
		180	50	22	31	36	34	29	23	19	—	22	31	36	35	30	23	19	—			
		240	65	39	39	42	42	37	32	30	16	39	39	42	43	38	32	30	16			
	1 200	120	33	10	19	28	23	18	—	—	—	10	20	28	24	18	10	—	—			
		180	50	22	31	36	34	29	23	19	—	22	31	36	35	30	23	19	—			
		240	65	39	39	42	42	37	32	30	16	39	39	42	43	38	32	30	16			
	1 350	120	33	10	21	29	25	20	11	—	—	10	23	30	28	21	12	—	—			
		180	50	23	32	38	36	31	25	18	—	22	34	39	38	32	26	20	—			
		240	65	41	41	44	44	38	35	32	19	39	42	45	45	40	36	32	21			
	1 500	120	33	10	21	29	25	20	11	—	—	10	23	30	28	21	12	—	—			
		180	50	23	32	38	36	31	25	18	—	22	34	39	38	32	26	20	—			
		240	65	41	41	44	44	38	35	32	19	39	42	45	45	40	36	32	21			
3-row design length in mm	1 050	180	50	9	21	27	27	14	12	—	—	9	21	27	27	19	10	—	—			
		250	70	18	29	34	35	25	22	14	—	18	30	33	35	28	23	14	—			
		320	90	29	36	39	41	33	30	25	12	29	37	37	41	34	32	26	11			
	1 200	180	50	9	21	27	27	14	12	—	—	9	21	27	27	19	10	—	—			
		250	70	18	29	34	35	25	22	14	—	18	30	33	35	28	23	14	—			
		320	90	29	36	39	41	33	30	25	12	29	37	37	41	34	32	26	11			
	1 350	180	50	9	25	31	31	20	14	—	—	9	25	32	32	21	15	—	—			
		250	70	18	33	38	39	29	26	18	—	18	34	39	40	30	27	19	—			
		320	90	30	40	43	45	36	35	29	17	29	41	43	45	37	36	30	17			
	1 500	180	50	9	25	31	31	20	14	—	—	9	25	32	32	21	15	—	—			
		250	70	18	33	38	39	29	26	18	—	18	34	39	40	30	27	19	—			
		320	90	30	40	43	45	36	35	29	17	29	41	43	45	37	36	30	17			
4-row design length in mm	1 050	240	65	10	21	27	28	15	13	—	—	10	22	28	29	16	14	—	—			
		320	90	17	29	34	35	25	22	14	—	17	30	34	36	26	23	15	—			
		400	111	27	35	38	40	32	29	23	10	27	36	39	41	33	30	24	10			
	1 200	240	65	10	21	27	28	15	13	—	—	10	22	28	29	16	14	—	—			
		320	90	17	29	34	35	25	22	14	—	17	30	34	36	26	23	15	—			
		400	111	27	35	38	40	32	29	23	10	27	36	39	41	33	30	24	10			
	1 350	240	65	10	25	32	32	20	15	—	—	10	26	32	32	21	16	—	—			
		320	90	17	33	38	39	29	26	18	—	17	34	38	40	30	27	19	—			
		400	111	27	39	42	44	35	34	27	15	27	40	43	44	36	35	26	16			
	1 500	240	65	10	25	32	32	20	15	—	—	10	26	32	32	21	16	—	—			
		320	90	17	33	38	39	29	26	18	—	17	34	38	40	30	27	19	—			
		400	111	27	39	42	44	35	34	27	15	27	40	43	44	36	35	26	16			
<b>IN-V3</b>																						
1-row design length in mm	1 050	40	11	13	20	29	25	17	—	—	—	13	21	29	26	20	—	—				
		50	14	20	26	32	32	24	10	—	—	20	27	32	32	27	10	—				
		60	16.5	28	31	35	37	29	20	10	—	28	32	35	37	32	20	13	—			
	1 200	40	11	13	20	29	25	17	—	—	—	13	21	29	26	20	—	—	—			
		50	14	20	26	32	32	24	10	—	—	20	27	32	32	27	10	—	—			
		60	16.5	28	31	35	37	29	20	10	—	28	32	35	37	32	20	13	—			
	1 350	40	11	16	24	29	30	22	—	—	—	16	25	30	31	23	12	—	—			
		50	14	25	30	34	35	29	20	—	—	25	31	34	37	30	21	10	—			
		60	16.5	36	35	35	40	34	26	16	14	36	36	37	41	35	27	18	16			
	1 500	40	11	16	24	29	30	22	—	—	—	16	25	30	31	23	12	—	—			
		50	14	25	30	34	35	29	20	—	—	25	31	34	37	30	21	10	—			
		60	16.5	36	35	35	40	34	26	16	14	36	36	37	41	35	27	18	16			

<sup>1)</sup> Sound power levels apply to volume flow damper in position "open"

# Adjustable induction outlet

## Sound power level – Return air <sup>1)</sup>

	Air outlet volume flow rate			Total pressure drop $\Delta p_t$ Pa	Connection with acoustic lining							Total pressure drop $\Delta p_t$ Pa	Connection without acoustic lining							
	$V_A$ m <sup>3</sup> / (h·m)		$l/(s·m)$		Sound power level $L_{W}$ in dB								Sound power level $L_{W}$ in dB							
	$L_{WA}$ dB(A)	Octave band centre frequency in Hz						$L_{WA}$ dB(A)	Octave band centre frequency in Hz											
	125	250	500	1 K	2 K	4 K		125	250	500	1 K	2 K	4 K		125	250	500	1 K	2 K	4 K
<b>IN-V2</b>																				
1-row design length in mm	1 050	60	16.5	11	21	20	25	20	11	—	—	11	21	22	26	20	11	—	—	—
		90	25	24	31	31	35	30	22	19	—	24	32	30	36	32	23	18	—	—
		120	33	41	38	39	42	37	30	27	18	42	40	36	43	40	32	31	19	—
	1 200	60	16.5	11	21	20	25	20	11	—	—	11	21	22	26	20	11	—	—	—
		90	25	24	31	31	35	30	22	19	—	24	32	30	36	32	23	18	—	—
		120	33	41	38	39	42	37	30	27	18	42	40	36	43	40	32	31	19	—
	1 350	60	16.5	12	22	25	26	22	12	—	—	12	24	26	28	23	13	—	—	—
		90	25	27	33	34	36	32	24	20	—	27	34	35	37	33	25	22	10	—
		120	33	47	40	41	43	39	32	30	20	47	41	42	44	40	33	31	22	—
	1 500	60	16.5	12	22	25	26	22	12	—	—	12	24	26	28	23	13	—	—	—
		90	25	27	33	34	36	32	24	20	—	27	34	35	37	33	25	22	10	—
		120	33	47	40	41	43	39	32	30	20	47	41	42	44	40	33	31	22	—
2-row design length in mm	1 050	120	33	11	23	28	26	22	14	10	—	11	24	29	28	23	13	11	—	—
		180	50	25	33	36	36	33	25	22	—	24	34	34	37	34	25	22	—	—
		240	65	44	41	42	43	41	33	33	21	42	42	41	44	41	34	34	22	—
	1 200	120	33	11	23	28	26	22	14	10	—	11	24	29	28	23	13	11	—	—
		180	50	25	33	36	36	33	25	22	—	24	34	34	37	34	25	22	—	—
		240	65	44	41	42	43	41	33	33	21	42	42	41	44	41	34	34	22	—
	1 350	120	33	13	24	31	27	22	15	—	—	13	25	32	30	22	17	—	—	—
		180	50	28	34	38	36	33	27	21	—	28	35	39	38	34	29	23	11	—
		240	65	50	42	43	42	41	35	33	22	50	43	44	44	42	37	35	24	—
	1 500	120	33	13	24	31	27	22	15	—	—	13	25	32	30	22	17	—	—	—
		180	50	28	34	38	36	33	27	21	—	28	35	39	38	34	29	23	11	—
		240	65	50	42	43	42	41	35	33	22	50	43	44	44	42	37	35	24	—
3-row design length in mm	1 050	180	50	12	24	28	25	25	14	—	—	12	25	31	28	24	16	—	—	
		250	70	23	32	35	35	31	25	18	—	23	33	36	36	32	26	20	—	—
		320	90	37	38	39	41	36	32	29	17	37	40	40	42	38	33	31	16	—
	1 200	180	50	12	24	28	25	25	14	—	—	12	25	31	28	24	16	—	—	—
		250	70	23	32	35	35	31	25	18	—	23	33	36	36	32	26	20	—	—
		320	90	37	38	39	41	36	32	29	17	37	40	40	42	38	33	31	16	—
	1 350	180	50	14	26	30	30	25	15	10	—	14	27	31	31	26	17	10	—	—
		250	70	26	34	37	38	33	26	22	—	26	35	37	39	34	27	23	—	—
		320	90	43	41	42	44	39	34	31	17	43	42	42	45	40	35	33	19	—
	1 500	180	50	14	26	30	30	25	15	10	—	14	27	31	31	26	17	10	—	—
		250	70	26	34	37	38	33	26	22	—	26	35	37	39	34	27	23	—	—
		320	90	43	41	42	44	39	34	31	17	43	42	42	45	40	35	33	19	—
4-row design length in mm	1 050	240	65	12	26	31	29	26	18	—	—	12	27	31	30	27	19	10	—	
		320	90	21	34	36	37	32	27	21	—	21	34	37	37	33	28	23	11	
		400	111	33	39	40	42	37	33	30	19	33	41	41	43	38	35	32	21	
	1 200	240	65	12	26	31	29	26	18	—	—	12	27	31	30	27	19	10	—	
		320	90	21	34	36	37	32	27	21	—	21	34	37	37	33	28	23	11	
		400	111	33	39	40	42	37	33	30	19	33	41	41	43	38	35	32	21	
	1 350	240	65	14	29	33	33	28	19	13	—	14	30	34	34	29	21	15	—	
		320	90	24	36	38	40	35	29	25	11	24	37	39	41	36	30	27	13	
		400	111	38	42	42	45	39	35	33	19	38	43	43	46	40	37	35	20	
	1 500	240	65	14	29	33	33	28	19	13	—	14	30	34	34	29	21	15	—	
		320	90	24	36	38	40	35	29	25	11	24	37	39	41	36	30	27	13	
		400	111	38	42	42	45	39	35	33	19	38	43	43	46	40	37	35	20	
<b>IN-V3</b>																				
1-row design length in mm	1 050	40	11	9	20	22	26	17	—	—	—	9	22	22	28	20	—	—	—	
		50	14	14	26	27	31	25	13	—	—	14	27	27	32	28	12	—	—	
		60	16.5	20	31	31	35	31	20	10	—	20	33	31	36	34	19	11	—	
	1 200	40	11	9	20	22	26	17	—	—	—	9	22	22	28	20	—	—	—	
		50	14	14	26	27	31	25	13	—	—	14	27	27	32	28	12	—	—	
		60	16.5	20	31	31	35	31	20	10	—	20	33	31	36	34	19	11	—	
	1 350	40	11	11	22	21	28	20	10	—	—	11	25	21	32	23	12	—	—	
		50	14	17	29	27	34	28	16	—	—	17	31	28	37	30	18	—	—	
		60	16.5	25	34	32	39	34	21	11	—	25	36	34	41	36	23	13	—	
	1 500	40	11	11	22	21	28	20	10	—	—	11	25	21	32	23	12	—	—	
		50	14	17	29	27	34	28	16	—	—	17	31	28	37	30	18	—	—	
		60	16.5	25	34	32	39	34	21	11	—	25	36	34	41	36	23	13	—	

<sup>1)</sup> Sound power levels apply to volume flow damper in position "open"

# Adjustable induction outlet

## Layout as return air inlet – Insertion loss

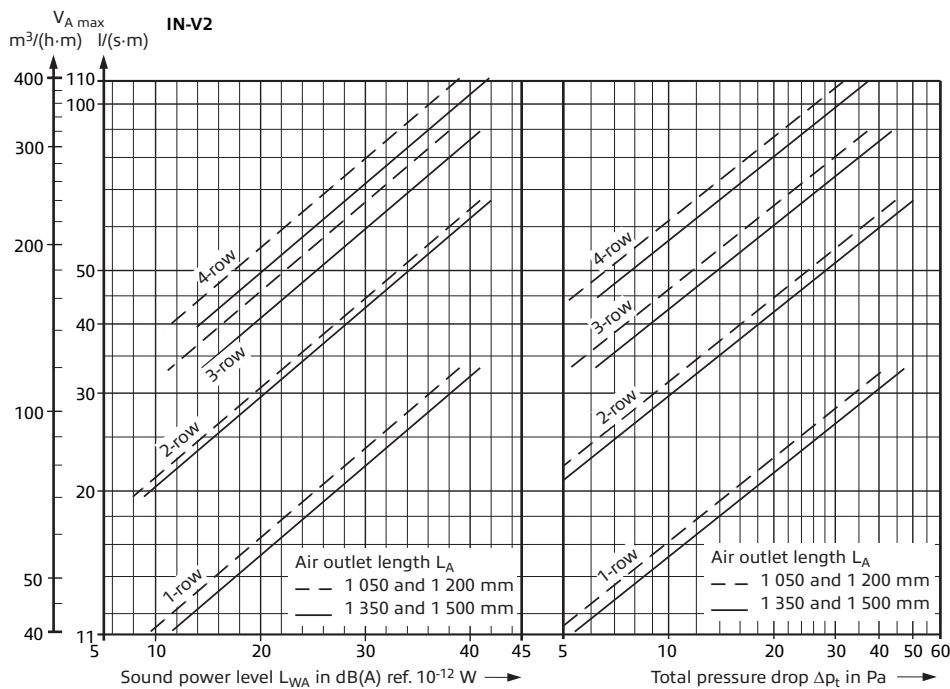

The graph values for sound power level and total pressure drop apply to an induction outlet with acoustic lining and open volume flow damper. If the damper is closed, the sound power level rises by 1 – 2 dB(A) ref.  $10^{-12}$  W while the pressure drop doubles.

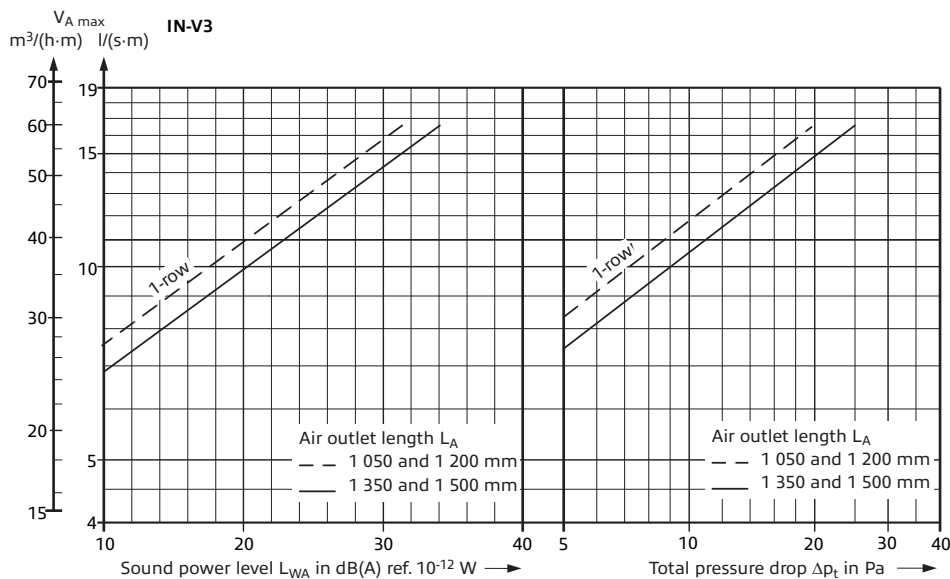

Insertionloss in dB								
Connection box with acoustic lining								
Octave band centre frequency in Hz								Mean value
125	250	500	1 K	2 K	4 K	8 K		
<b>IN-V2</b>								
1-row	1	6	8	17	11	13	14	10
2-row	3	6	11	12	12	15	12	10
3-row	3	4	9	8	9	12	9	7
4-row	2	4	9	7	8	10	9	7
<b>IN-V3</b>								
1-row	3	7	11	20	14	11	14	11

Insertionloss in dB								
Connection box without acoustic lining								
Octave band centre frequency in Hz								Mean value
125	250	500	1 K	2 K	4 K	8 K		
1	3	7	10	6	8	9	6	
2	6	8	10	8	11	10	8	
3	4	5	4	4	6	7	5	
2	3	5	4	4	5	7	4	
2	3	4	12	12	7	10	7	

### Features

- Single jets discharged in alternate directions or in one direction only, jet direction adjustable from horizontal to vertical; outlet protected against unintentional alteration of setting (IN-V2 only)
- Two types available
  - IN-V2 in 1-row to 4-row design,  
volume flow rate 11 to 111 l/(s·m) [40 to 400 m<sup>3</sup>/(h·m)]
  - IN-V3 in one-row design,  
volume flow rate 3 to 17 l/(s·m) [10 to 60 m<sup>3</sup>/(h·m)]
- Usable as supply air outlet or return air inlet
- Good visual integration into ceiling thanks to small width of visible air outlet profile, in particular that of IN-V3 (only 15 mm wide)
- Subsequent installation of diffuser element possible from the room (e.g. for plasterboard ceilings)
- Discharge heights: from 2.7 to 5 m with IN-V2, from 2.5 to 3.5 m with IN-V3
- Max. temperature difference between supply air and indoor air: -10 K when cooling, +6 K when heating
- Low sound power level
- Optional volume flow damper adjustable from room
- Connection box optionally fitted with acoustic lining; connection spigot available with or without seal
- Lengths: 1 050 mm, 1 200 mm, 1 350 mm and 1 500 mm (other lengths on request)
- Air outlets easy to mount in lines; alignment pieces are provided with the outlets to enable exact alignment
- Blank elements (without connection boxes) are available as options where continuous lines of outlets are required
- Air outlet profile made of aluminium anodized in natural colour or painted to RAL 9010 pure white<sup>1)</sup>, discharge element made of polycarbonate (body-tinted in black similar to RAL 9005 or in white similar to RAL 9010) <sup>1)</sup>, connection box made of galvanized sheet metal

---

<sup>1)</sup> Other colour for air outlet profile or discharge element on request

# Adjustable induction outlet

## Type code IN-V2

### Type code IN-V2

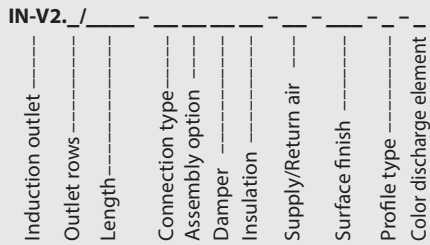

#### Outlet rows (only IN-V2)

1	=	1-row	3	=	3-rows
2	=	2-rows	4	=	4-rows

#### Length

1050	=	1 050 mm	1350	=	1 350 mm
1200	=	1 200 mm	1500	=	1 500 mm

#### Connection type

AK	=	Connection box
BO	=	blank element, open at the rear, for continuous lines of outlets, without connection box
BG	=	blank element, closed at the rear, for continuous lines of outlets, without connection box

#### Assembly option

M	=	Installation of diffuser element from room
S	=	expansion bracket for blank element
O	=	blank element without expansion bracket

#### Damper

O	=	no volume flow damper
R	=	with volume flow damper adjustable from room

#### Insulation

O	=	without acoustic lining
I	=	with acoustic lining

#### Supply/Return air

Z1	=	supply air, for alternate discharge 0 – 20°
Z2	=	supply air, for alternate discharge 0 – 40° (standard)
Z3	=	supply air, for 1-way discharge, air flow directed to spigot site
Z4	=	supply air, for 1-way discharge, air flow directed opposite to spigot site
AB	=	return air

#### Surface finish

elox	=	aluminium anodized in natural colour (E6EV1)
9010	=	face painted to RAL 9010, semi-matt
...	=	face painted to RAL ...

#### Profile type

A	=	flush contact profile
D	=	ceiling support profile

#### Color discharge element

S	=	black similar to RAL 9005
W	=	white similar to RAL 9010

### Type code IN-V3

IN-V3.1/ \_\_\_\_\_ - \_\_\_\_\_ - \_\_\_\_\_ - \_\_\_\_\_ - \_\_\_\_\_ - \_\_\_\_\_ - \_\_\_\_\_ - \_\_\_\_\_  
 Induction outlet \_\_\_\_\_  
 Outlet rows \_\_\_\_\_  
 Length \_\_\_\_\_  
 Connection type \_\_\_\_\_  
 Assembly option \_\_\_\_\_  
 Damper \_\_\_\_\_  
 Insulation \_\_\_\_\_  
 Supply/Return air \_\_\_\_\_  
 Surface finish \_\_\_\_\_  
 Profile type \_\_\_\_\_  
 Color discharge element \_\_\_\_\_

#### Length

1050 = 1 050 mm    1350 = 1 350 mm  
 1200 = 1 200 mm    1500 = 1 500 mm

#### Connection type

AK = Connection box  
 BO = blank element, open at the rear, for continuous lines of outlets, without connection box  
 BG = blank element, closed at the rear, for continuous lines of outlets, without connection box

#### Assembly option

V = Connection box/diffuser element assembly  
 S = expansion bracket for blank element  
 O = blank element without expansion bracket

#### Damper

O = no volume flow damper  
 R = with volume flow damper adjustable from room

#### Insulation

O = without acoustic lining  
 I = with acoustic lining

#### Supply/Return air

Z = Supply air  
 A = Return air

#### Surface finish

elox = aluminium anodized in natural colour (E6EV1)  
 9010 = face painted to RAL 9010, semi-matt  
 ... = face painted to RAL ...

#### Profile type

A = flush contact profile  
 D = ceiling support profile

#### Color discharge element

S = black similar to RAL 9005  
 W = white similar to RAL 9010



# Adjustable induction outlet

## Tender text

### Tender text

..... units

#### Adjustable induction outlet <sup>1)</sup>

of small width, with high induction effect for diffuse indoor air flow and high thermal comfort in the occupied zone, well suited for installation in suspended ceiling systems, with discharge direction adjustable from horizontal to vertical as required, for use as supply air outlet or return air inlet,

consisting of:

- linear discharge element with consecutive cylindrical and rotatable single elements for alternate air discharge to the right and to the left or one-sided air discharge, or even in closed position; 1-row to 4-row design (only 1-row design for IN-V3)
- air outlet profile for lateral attachment of false ceiling, or with ceiling support profile
- connection box with endwise suspension brackets; optional volume flow damper adjustable from room; optional acoustic lining (Building material class B1 according to DIN 4102-1); optional seal at connection spigot; connection box for IN-V2 optionally prepared for subsequent mounting of diffuser element from the room

#### Material:

- Linear discharge element made of polycarbonate, body-tinted in black similar to RAL 9005 <sup>2)</sup> or white similar to RAL 9010 <sup>2)</sup>
- Air outlet profile made of aluminium anodized in natural colour or painted to RAL 9010 <sup>2)</sup>, pure white
- Ceiling support profile made of aluminium anodized in natural colour or painted to RAL 9010 <sup>2)</sup>, pure white
- Connection box made of galvanized sheet metal

Producer: Krantz GmbH

Make: Adjustable induction outlet

Type code: IN-V\_ \_

Example: IN-V2 – 3 – 1200 – KO – M – R – I – Z3 – 9010 – A – W

#### Blank element

..... units

Induction outlet with linear discharge element and air outlet profile as described before, but without connection box, as blank element for continuous lines of outlets where required, open or closed at the rear; for IN-V2 optional fastening with expansion brackets

#### Accessories

..... units

Corner piece for outlet arrangement at 90°, to fit air outlet profile and linear discharge element as described before

..... units

Endwise angle piece to fit ceiling support profile as described before, supplied loose, with boreholes and fastening screws

Producer: Krantz GmbH

Make: Adjustable induction outlet

Type code: IN-V\_ \_

Example: IN-V3 – 1 – 1500 – KD – O – O – O – Z – 9010 – A – S

Subject to technical alterations.

<sup>1)</sup> If the adjustable induction outlet is required for use as return air inlet, the tender text is the same as for the supply air outlet

<sup>2)</sup> Other lengths and colours on request

## Krantz GmbH

Uersfeld 24, 52072 Aachen, Deutschland

Tel.: +49 241 441-1

Fax: +49 241 441-555

info@krantz.de | www.krantz.de

