

**Krantz**

**Induction unit for mixing ventilation  
IG-M-SB  
for vertical parapet mounting**

**Cooling and heating systems**

*Krantz*

# Induction unit for mixing ventilation

## for vertical parapet mounting

### Preliminary remark

For removing cooling and heating loads from building whose facades are fitted with window parapets, Krantz provides induction units for mixing ventilation, designed for vertical parapet mounting. As these units have a height of 450 mm only (inclusive of air outlet), they are particularly suitable for refurbishment projects where there is little space available.

In new buildings, the low unit height makes it possible to have low parapet heights, all the more as a part of the induction unit can be set in the raised floor.

The induction unit for mixing ventilation belongs to the line of air-and-water systems where the outdoor air flow rate required for reasons of hygiene is conditioned in a central air handling unit and the cooling or heating load removed via a 4-pipe water system. Air-and-water systems are much more economical than pure air systems (such as VAV systems).

### Construction design and mode of operation

The induction unit for mixing ventilation – for vertical parapet mounting – consists of a housing **1** with primary air connection **2**. Inside the primary air box **3**, the primary air is conveyed by nozzles **4** to the induction area **5** in front of the heat exchanger **6**. The heat exchanger has usually a 4-pipe design, yet a 2-pipe design can be provided on request in the case change-over operation is required. The waterside control valves can be positioned near or beneath the unit.

Owing to the suction effect of the nozzle jets, secondary air **7** is sucked in via the heat exchanger **6** where it is either heated or cooled. The blend of primary and secondary air forms supply air **8** which is discharged by the air outlet **9** in front of the facade or glazing **10**. The induction unit is encased in the parapet cover **11** provided by the client. If condensate forms, it will be removed via the condensate drain **12**.

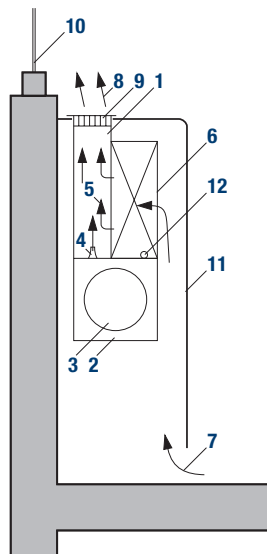
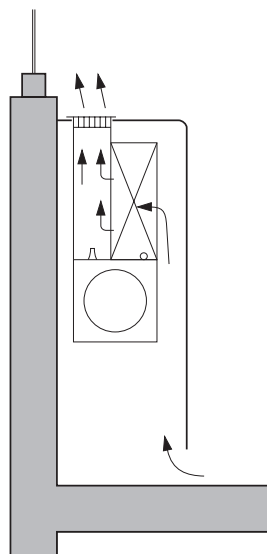

**Fig. 1: Design and mode of operation of the induction unit for mixing ventilation – for vertical parapet mounting – when cooling and heating**

#### Key

- |                                 |                             |
|---------------------------------|-----------------------------|
| <b>1</b> Housing                | <b>7</b> Secondary air      |
| <b>2</b> Primary air connection | <b>8</b> Supply air         |
| <b>3</b> Primary air box        | <b>9</b> Bar outlet         |
| <b>4</b> Nozzle                 | <b>10</b> Facade or glazing |
| <b>5</b> Induction area         | <b>11</b> Parapet cover     |
| <b>6</b> Heat exchanger         | <b>12</b> Condensate drain  |

When heating at weekends or at night, primary air is not required; the induction unit then operates with self-convection, which saves energy (see Fig. 2)



**Fig. 2: Operation with self-convection**

# Induction unit for mixing ventilation

## for vertical parapet mounting

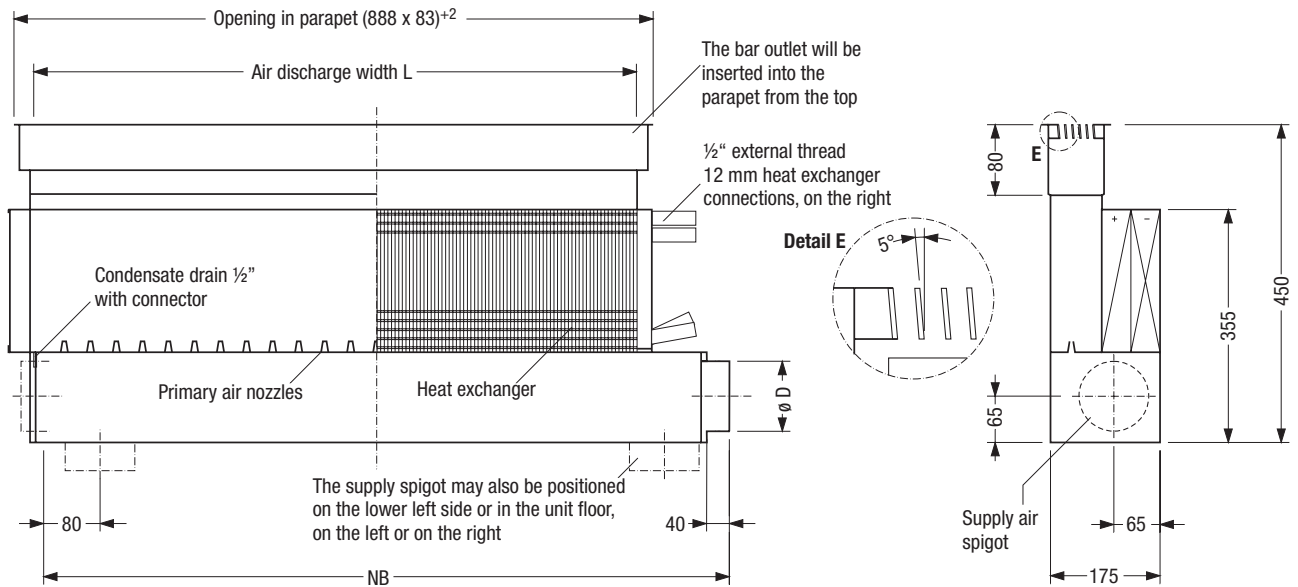

Frontal plate painted to RAL 9010 (pure white), other colours available on request

Nominal unit width	Air discharge width	Connection spigot f. primary air, D in mm		Weight
		Nozzle diameter in mm		
NB mm	L mm	7 and 8	10	Approx. kg
800	610	99	99	17.5
1000	810	99	124	20.0
1200	1010	124	124	23.0

Fig. 3: Unit dimensions

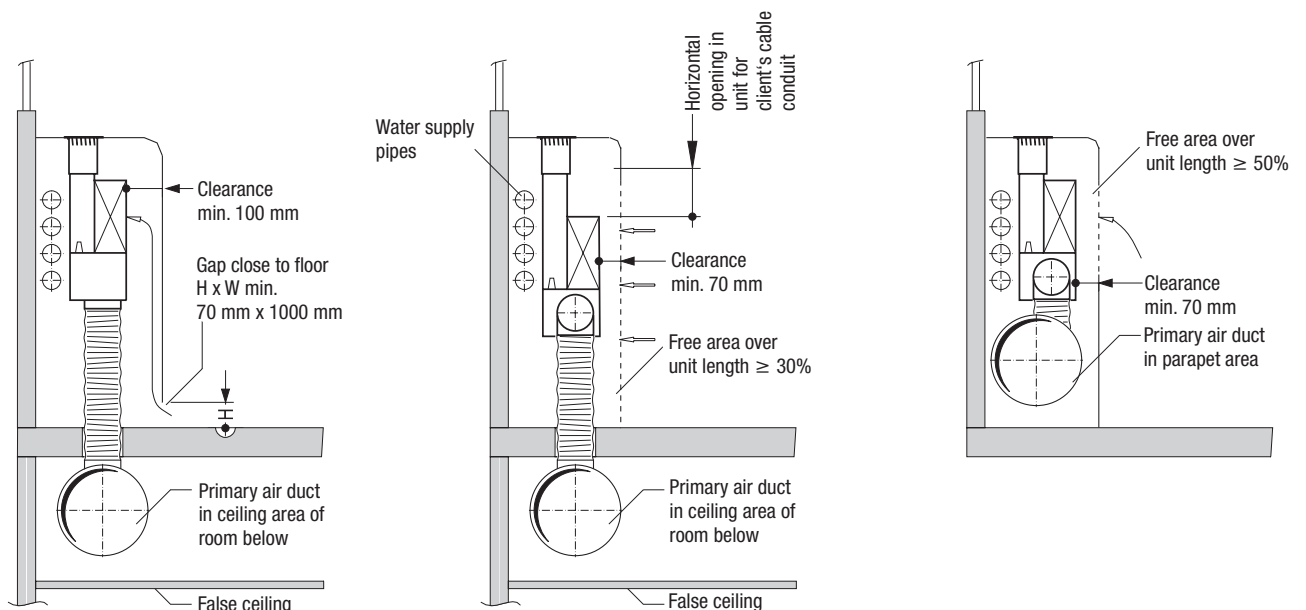

Fig. 4: Examples of possible secondary air openings in client's parapet cover

Left: Gap close to floor

Middle: Large grille or perforated plate

Right: Horizontal grille or perforated plate only in front of the heat exchanger

# Induction unit for mixing ventilation

## for vertical parapet mounting

### Technical selection

#### Cooling

The cooling output of the induction unit is made up of the water-side (secondary air) and primary air-side cooling outputs. **Table 1** shows a preselection.

**Table 1: Preselection for cooling for  $\Delta p = 170 \text{ Pa}$  and  $L_{WA} \leq 29 \text{ dB(A)}$**

Nominal unit width mm	Primary air volume flow rate		Nozzle diameter mm	Water flow l/h	Cooling output <sup>1)</sup> Secondary air W	Cooling output <sup>2)</sup> Primary air W	Total cooling output W	Total specific cooling output <sup>3)</sup> W/m <sup>2</sup>
	l/s	m <sup>3</sup> /h						
800	8	30	7	134	312	81	392	65
	13	45	8	174	406	121	527	87
	17	60	10	192	448	161	609	101
1000	13	45	7	202	471	121	592	83
	17	60	8	232	541	161	702	98
	24	85	10	267	623	228	851	119
1200	17	60	7	270	630	161	791	96
	22	80	8	307	716	215	931	113
	29	105	10	331	771	282	1054	128

<sup>1)</sup> Supply/Return temperature 15/17 °C, primary and secondary air temperature 26 °C

<sup>2)</sup> Primary air temperature 18 °C, room temperature 26 °C

<sup>3)</sup> Example of room axis-to-axis dimension:  
(nominal unit width + 300 mm) x room depth 5.5 m

The water-side cooling output, which is delivered via the secondary air, is dependent on the primary air volume flow rate and the difference between mean water temperature and indoor air temperature. **Graph 1** shows standard outputs per metre of air discharge width 'L' for a difference of -10 K, e.g. room temperature 26 °C, supply temperature 15 °C, return temperature 17 °C and mean water temperature 16 °C. For other layout cases, the outputs shown in **Graph 1** can be converted in a linear way, e.g. for a difference of -8 K instead of -10 K between mean water temperature and indoor air temperature, the conversion factor is -8/-10 K and, thus, the conversion is 0.8 x output as per **Graph 1**.

If a pressure drop higher than 170 Pa or a sound power level higher than 29 dB(A) ref. 10<sup>-12</sup> W is allowable, the maximum specific primary air volume flow rates can be selected according to **Graph 5** at the relevant nozzle diameters.

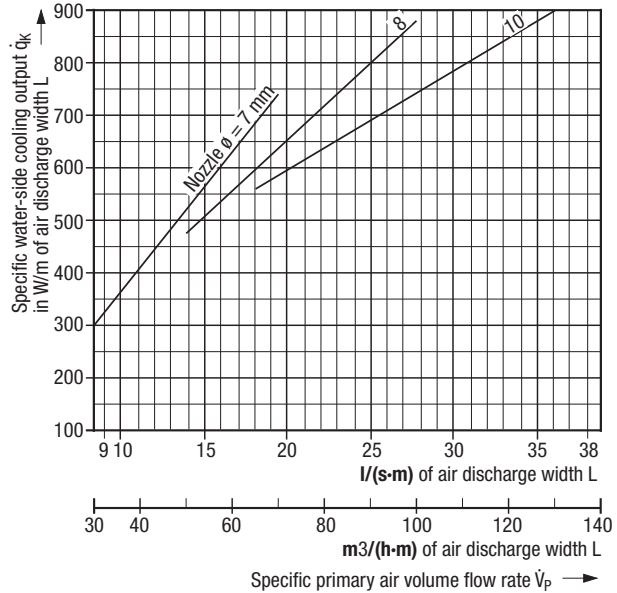

**Graph 1: Specific water-side cooling output at a difference of -10 K between mean water temperature and secondary air temperature**

The primary air-side cooling output depends on the primary air volume flow rate and the difference between supply air and indoor air temperatures. The standard layout is often made at a difference of -8 K, i.e. with a primary air temperature of 18 °C and an indoor air temperature of maximum 26 °C. **Graph 2** shows cooling outputs for this and other temperature differences, in relation to the primary air volume flow rate. The outputs are independent of the unit size, i.e. they are influenced only by the primary air volume flow rate and the temperature difference.

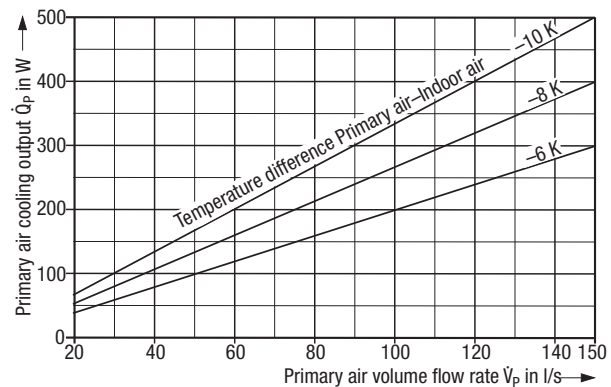

**Graph 2: Primary air-side cooling output**

The total cooling output of the induction unit is the sum of primary air output and secondary air output (water-side).

# Induction unit for mixing ventilation

## for vertical parapet mounting

### Heating

The heating output of the induction unit is delivered economically via the secondary air, i.e. via the heat exchanger. Values are given in **Table 2** for various nominal unit widths and nozzle diameters in order to facilitate the preselection. Additional heating output can be delivered via the primary air but, as a rule, this is not necessary because of the high water-side outputs.

In winter, if the primary air is supplied at a temperature lower than that of the indoor air, additional heating is required which, besides transmission heat losses of the building, is to be covered by the secondary air. This is for instance the case when other interior spaces are to be provided with cooling from the central plant in winter too.

**Table 2: Preselection for heating for  $\Delta p = 170 \text{ Pa}$  and  $L_{WA} \leq 29 \text{ dB(A)}$**

Nominal unit width	Primary air volume flow rate		Nozzle diameter	Water flow	Heating output <sup>1)</sup> Secondary air	Specific heating output <sup>2)</sup>
	l/s	m <sup>3</sup> /h				
mm	l/s	m <sup>3</sup> /h	mm	l/h	W	W/m <sup>2</sup>
800	8	30	7	77	449	74
	13	45	8	89	517	85
	17	60	10	96	556	92
1000	13	45	7	110	638	89
	17	60	8	118	688	96
	24	85	10	132	766	107
1200	17	60	7	142	826	100
	22	80	8	154	893	108
	29	105	10	163	950	115

<sup>1)</sup> Supply/Return temperature 45/40 °C, primary and secondary air temperature 22 °C

<sup>2)</sup> Example of room axis-to-axis dimension: (nominal unit width + 300 mm) x room depth 5.5 m

**Graph 3** shows outputs for a difference of 20 K between mean water temperature and room temperature. Other values can be converted in a linear way.

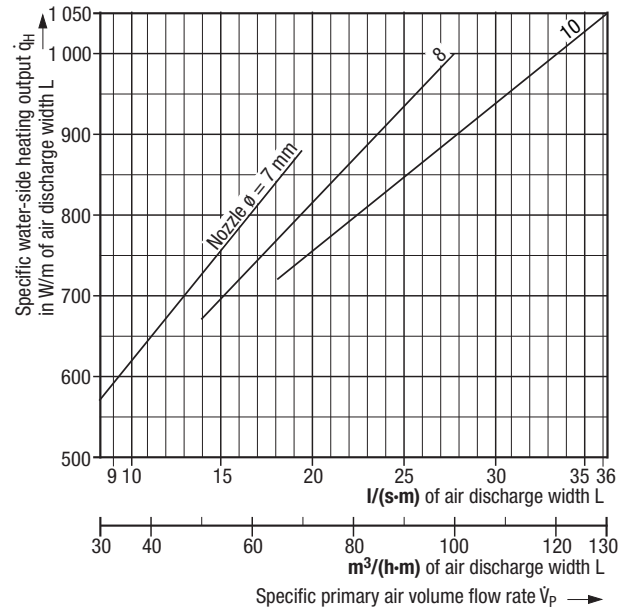

**Graph 3: Specific water-side heating output at a difference of +20 K between mean water temperature and secondary air temperature**

The induction unit can also be operated with pure self-convection, without primary air (**Fig. 2** on page 2).

For the purposes of economy this is mainly used at night and at weekends. Related heating outputs can be read off **Graph 4**; they apply for a water flow rate of 70 l/h. At a higher water flow rate, the heating output rises a little, e.g. by 3% at 100 l/h.

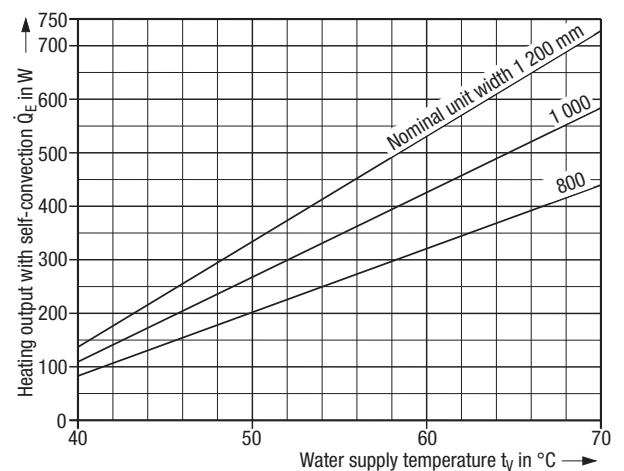

**Graph 4: Heating output with self-convection, room temperature 22 °C, water flow rate 70 l/h**

# Induction unit for mixing ventilation

## for vertical parapet mounting

### Sound power level and pressure drop

The sound power level is shown in **Graph 5** in relation to the specific primary air volume flow rate.

To read it from the **graph**, you must first adapt the volume flow rate of the selected nominal unit width to the air discharge width (see **Fig. 3** on page 3).

Example:

Nominal unit width:	1 000 mm
Air discharge width:	810 mm
Primary air volume flow rate:	60 m <sup>3</sup> /h
Specific primary air volume flow rate, related to air discharge width:	20 l/(s·m) [74 m <sup>3</sup> /(h·m)]
Nozzle diameter:	8 mm
Sound power level:	27 dB(A) ref. 10 <sup>-12</sup> W

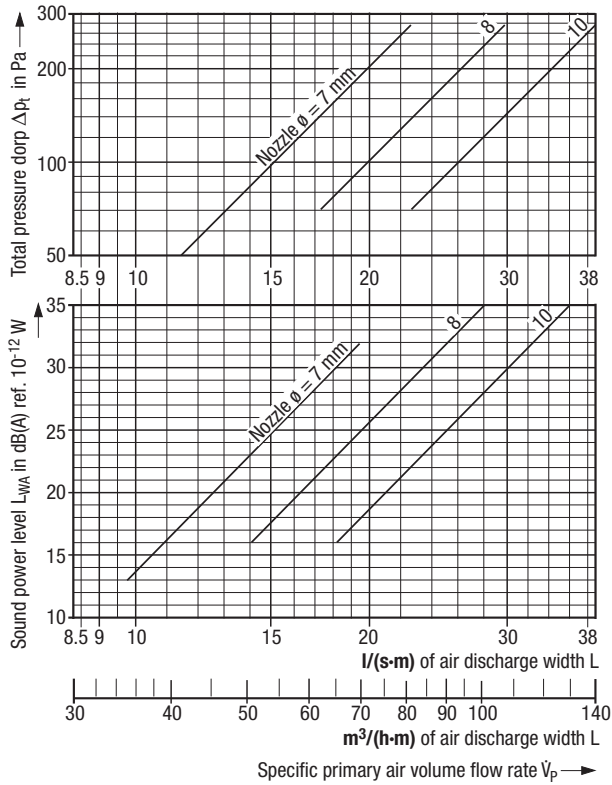

**Graph 5: Sound power level and primary air-side pressure drop**

The pressure drop on the primary air side can be read off **Graph 5**. For this, you must first adapt the volume flow rate of the selected unit to the specific primary air flow rate, in relation to the air discharge width (see **Fig. 3** on page 3).

The pressure drop on the water side, i.e. in the secondary air heat exchanger, is shown in **Graph 6** for heating and cooling respectively.

The minimum water flow rate for all unit sizes is 70 l/h.

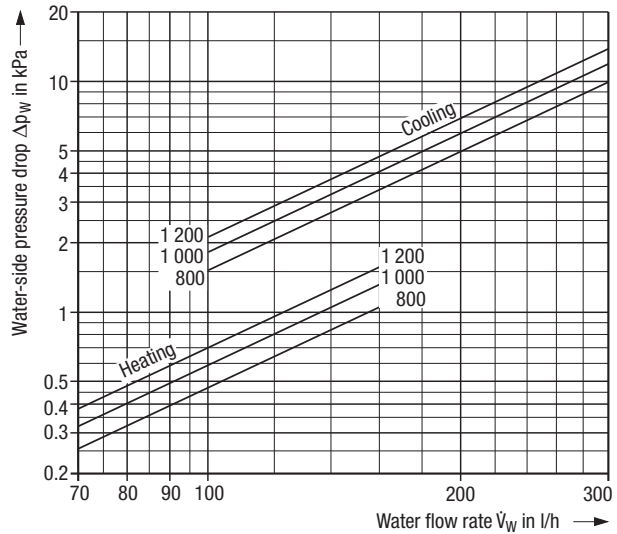

**Graph 6: Water-side pressure drop of heat exchanger**

# Induction unit for mixing ventilation

## for vertical parapet mounting

### Features

- For cooling, heating, and fresh air supply along the facade, through window parapets; high level of thermal comfort
- Primary air volume flow rate: 8 to 36 l/s [30 to 130 m<sup>3</sup>/h]
- Low pressure drop (70 to 200 Pa), therefore energy-saving operation
- Low sound power level
- Heating also possible without primary air, which saves energy when heating at night and at weekends
- Heat exchanger cleanable from the front and the rear (in compliance with requirements of VDI 6022).
- The large fin spacing enables easy cleaning and obviates the need for a filter.
- Suitable for new or refurbished buildings
- Condensate tank below heat exchanger, inclusive of drain socket with ½" connector

### Type code

<b>IG - M - SB -</b>	
Induction unit	<b>Placement</b> SB = vertical parapet mounting <b>Nominal unit width</b> 800, 1 000 and 1 200
Mixing ventilation	
Placement	
Nominal unit width	

### Tender text

..... units

Induction unit for mixing ventilation – for vertical parapet mounting – for cooling, heating, and fresh air supply along the facade through window parapets

Item 1

**Unit** with primary air connection and built-in metallic primary air nozzles,

consisting of:

- water heat exchanger made from copper piping with aluminium fins and separate circuits for heating and cooling; large fin spacing for easy cleaning as per VDI 6022;
- condensate tank inclusive of drain with ½" connector;
- primary air box with inspection opening as per VDI 6022;
- water connection on the left or right ½" external thread.

Item 2

**Air outlet element** with bars parallel to the facade for screening of glazed facade when cooling or heating; quick jet velocity decay without formation of uncomfortable tangential air patterns.

### Technical data

Primary air volume flow rate: ..... l/s [m<sup>3</sup>/h]  
 Permissible sound power level: ..... dB(A) ref. 10<sup>-12</sup> W  
 Pressure drop on air side: ..... Pa

#### Cooling mode

Total cooling output: ..... W  
 Water supply temperature: ..... °C  
 Water flow rate: ..... l/h  
 Pressure drop on water side: ..... kPa

#### Heating mode

Heating output (secondary): ..... W  
 Water supply temperature: ..... °C  
 Water flow rate: ..... l/h  
 Pressure drop on water side: ..... kPa

#### Material

Housing: galvanized sheet metal  
 Air outlet element: aluminium  
 painted to RAL 9010 (pure white) <sup>1)</sup>  
 Heat exchanger: copper / aluminium

#### Dimensions

Nominal unit width <sup>2)</sup>: ..... mm  
 Depth: ..... mm  
 Height: ..... mm

Permissible operating pressure of heat exchanger: 16 bars

Make: Krantz  
 Type: IG - M - SB - \_\_

Subject to technical alteration.

<sup>1)</sup> Other colours available on request

<sup>2)</sup> Consult us for other sizes

---

**Krantz GmbH**

Uersfeld 24, 52072 Aachen, Germany

Phone: +49 241 441-1

Fax: +49 241 441-555

info@krantz.de | [www.krantz.de](http://www.krantz.de)

The logo for Krantz GmbH, featuring the word "Krantz" in a stylized, blue, cursive script font.